

# GBU10/15/25 SERIES



## GLASS PASSIVATED BRIDGE RECTIFIERS

REVERSE VOLTAGE - 50 to 1000Volts  
FORWARD CURRENT - 10/15/25 Amperes

### FEATURES

- Surge overload rating -220~350 amperes peak
- Ideal for printed circuit board
- Reliable low cost construction utilizing molded plastic technique
- Plastic material has U/L flammability classification 94V-0
- Mounting position: Any

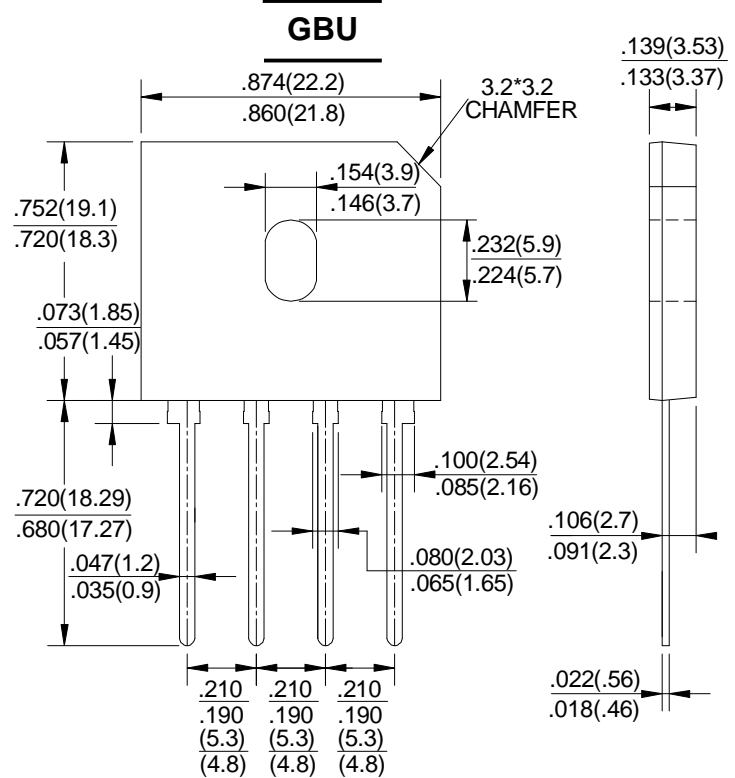

Dimensions in inches and (millimeters)

### MAXIMUM RATINGS AND ELECTRICAL CHARACTERISTICS

Rating at 25°C ambient temperature unless otherwise specified.

Single phase, half wave ,60Hz, resistive or inductive load.

For capacitive load, derate current by 20%

CHARACTERISTICS	SYMBOL	GBU	GBU	GBU	GBU	GBU	GBU	GBU	UNIT
		10A 15005 25005	10B 1501 2501	10D 1502 2502	10G 1504 2504	10J 1506 2506	10K 1508 2508	10M 1510 2510	
Maximum Recurrent Peak Reverse Voltage	V <sub>RRM</sub>	50	100	200	400	600	800	1000	V
Maximum RMS Voltage	V <sub>RMS</sub>	30	70	140	280	420	560	700	V
Maximum DC Blocking Voltage	V <sub>DC</sub>	50	100	200	400	600	800	1000	V
Maximum Average Forward (with heatsink Note 2) Rectified Current @ T <sub>C</sub> =100°C (without heatsink)	I <sub(av)< sub=""></sub(av)<>	GBU 10	10 3.0	GBU 15	15 3.2	GBU 25	25 4.2		A
Peak Forward Surge Current 8.3ms Single Half Sine-Wave Super Imposed on Rated Load (JEDEC Method)	I <sub>FSM</sub>		220		240		350	A	
Maximum Forward Voltage at 5.0/7.5/12.5A DC	V <sub>F</sub>	1.1						V	
Maximum DC Reverse Current @ T <sub>J</sub> =25°C at Rated DC Blocking Voltage @ T <sub>J</sub> =125°C	I <sub>R</sub>	10.0 500						uA	
I <sup>2</sup> t Rating for Fusing (t<8.3ms)	I <sup>2</sup> t	200						A <sup>2</sup> s	
Typical Junction Capacitance Per Element (Note1)	C <sub>J</sub>	70						pF	
Typical Thermal Resistance (Note2)	R <sub>θJC</sub>	2.2						°C/W	
Operating Temperature Range	T <sub>J</sub>	-55 to +150						°C	
Storage Temperature Range	T <sub>STG</sub>	-55 to +150						°C	

NOTES: 1. Measured at 1.0MHz and applied reverse voltage of 4.0V DC.

2. Device mounted on 100mm\*100mm\*1.6mm cu plate heatsink.

# RATING AND CHARACTERISTIC CURVES

## GBU10/15/25 SERIES

FIG.1-MAXIMUM FORWARD SURGE CURRENT

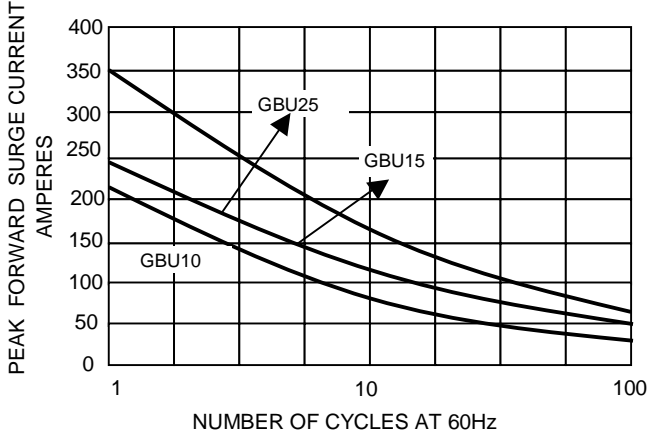

FIG.2- DERATING CURVE  
OUTPUT RECTIFIED CURRENT

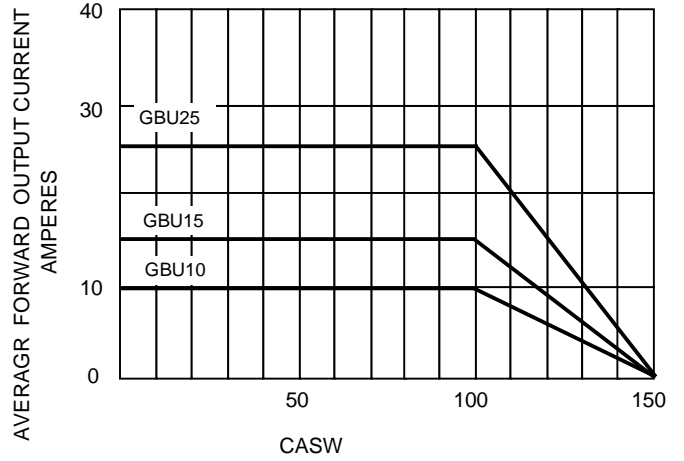

FIG.3-TYPICAL FORWARD CHARACTERISTICS

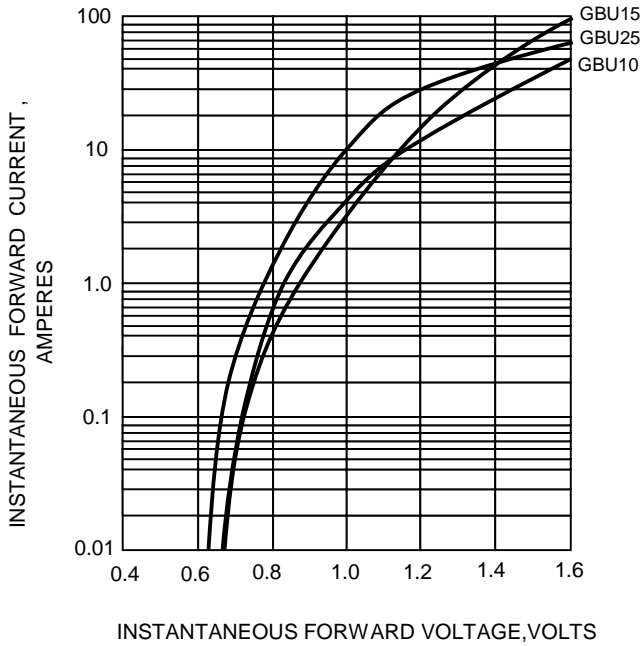

FIG.4-TYPICAL REVERSE CHARACTERISTICS

