

# 1N4729AW THRU 1N4761AW

1.0 Watt Zener Diode 3.6 to 75 Volts



## Features

- Silicon planar power zener diodes
- Low profile surface-mount package
- Lead Free Finish/Rohs Compliant ("P" Suffix designates Rohs Compliant. See ordering information)
- Moisture Sensitivity: Level 1

## Maximum Ratings

- Operating Temperature: -55°C to +150°C
- Storage Temperature: -55°C to +150°C

## Electrical Characteristics @ 25°C Unless Otherwise Specified

DC Power Dissipation	$P_d$	1.0W	$T_A=25^\circ\text{C}$
Forward Voltage Drop	$V_F$	1.2V	
Thermal Resistance	$R_{thJA}$	100K/W	Note 1
Power Derating from 100°C	$P_{tot}$	10mW/°C	

**Note:** (1) Valid provided that electrodes at a distance of 10mm from case are kept at ambient temperature.

## SOD123

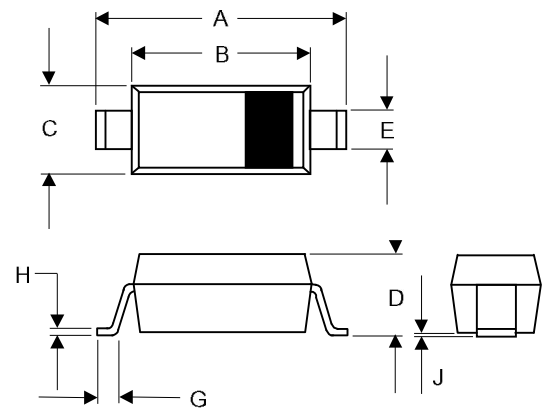

DIM	DIMENSIONS				NOTE
	INCHES		MM		
	MIN	MAX	MIN	MAX	
A	.140	.152	3.55	3.85	
B	.100	.112	2.55	2.85	
C	.055	.071	1.40	1.80	
D	-----	.053	-----	1.35	
E	.012	.031	0.30	.78	
G	.006	-----	0.15	-----	
H	-----	.01	-----	.25	
J	-----	.006	-----	.15	

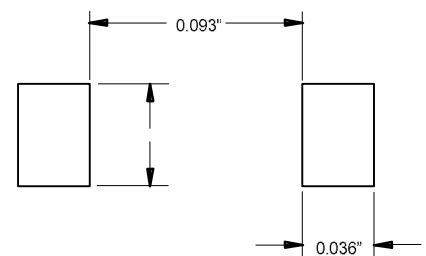

# 1N4729AW thru 1N4761AW

## Electrical Characteristics (T<sub>A</sub> = 25°C unless otherwise noted). Maximum V<sub>F</sub> = 1.2V at I<sub>F</sub> = 200mA

MCC Part Number	Zener Voltage	Test Current	Maximum Dynamic Impedance			Maximum Reverse Leakage Current		Surge Current	Maximum Regulator Current	Device Marking
			Z <sub>ZT</sub> @I <sub>ZT</sub>	Z <sub>ZK</sub> @I <sub>ZK</sub>	I <sub>ZK</sub>	I <sub>R</sub> @V <sub>R</sub>	V <sub>R</sub>			
	V <sub>Z</sub> @I <sub>ZT</sub>	I <sub>ZT</sub>	Z <sub>ZT</sub> @I <sub>ZT</sub>	Z <sub>ZK</sub> @I <sub>ZK</sub>	I <sub>ZK</sub>	I <sub>R</sub> @V <sub>R</sub>	V <sub>R</sub>	I <sub>R</sub>	I <sub>ZM</sub>	
	Volts	mA	OHMS	OHMS	mA	uA	Volts	mA	mA	
1N4729AW	3.6	69	10	400	1	100	1	1260	252	729
1N4730AW	3.9	64	9	400	1	50	1	1190	234	730
1N4731AW	4.3	58	9	400	1	10	1	1070	217	731
1N4732AW	4.7	53	8	500	1	10	1	970	193	732
1N4733AW	5.1	49	7	550	1	10	1	890	178	733
1N4734AW	5.6	45	5	600	1	10	2	810	162	734
1N4735AW	6.2	41	2	700	1	10	3	730	146	735
1N4736AW	6.8	37	3.5	700	1	10	4	660	133	736
1N4737AW	7.5	34	4	700	0.5	10	5	605	121	737
1N4738AW	8.2	31	4.5	700	0.5	10	6	550	110	738
1N4739AW	9.1	28	5	700	0.5	10	7	500	100	739
1N4740AW	10	25	7	700	0.25	10	7.6	454	91	740
1N4741AW	11	23	8	700	0.25	5	8.4	414	83	741
1N4742AW	12	21	9	700	0.25	5	9.1	380	76	742
1N4743AW	13	19	10	700	0.25	5	9.9	344	69	743
1N4744AW	15	17	14	700	0.25	5	11.4	304	61	744
1N4745AW	16	15.5	16	700	0.25	5	12.2	285	57	745
1N4746AW	18	14	20	750	0.25	5	13.7	250	50	746
1N4747AW	20	12.5	22	750	0.25	5	15.2	225	45	747
1N4748AW	22	11.5	23	750	0.25	5	16.7	205	41	748
1N4749AW	24	10.5	25	750	0.25	5	18.2	190	38	749
1N4750AW	27	9.5	35	750	0.25	5	20.6	170	34	750
1N4751AW	30	8.5	40	1000	0.25	5	22.8	150	30	751
1N4752AW	33	7.5	45	1000	0.25	5	25.1	135	27	752
1N4753AW	36	7	50	1000	0.25	5	27.4	125	25	753
1N4754AW	39	6.5	60	1000	0.25	5	29.7	115	23	754
1N4755AW	43	6	70	1500	0.25	5	32.7	110	22	755
1N4756AW	47	5.5	80	1500	0.25	5	35.8	95	19	756
1N4757AW	51	5	95	1500	0.25	5	38.8	90	18	757
1N4758AW	56	4.5	110	2000	0.25	5	42.6	80	16	758
1N4759AW	62	4	125	2000	0.25	5	47.1	70	14	759
1N4760AW	68	3.7	150	2000	0.25	5	51.7	65	13	760
1N4761AW	75	3.3	175	2000	0.25	5	56	60	12	761

**Note** 1: V<sub>Z</sub>: tolerance +/-5%

- 2: The Zener impedance is derived from the 60 Hz ac voltage, which results when an ac current having an rms value equal to 10% of the DC Zener current(I<sub>ZT</sub> or I<sub>ZK</sub>) is superimposed on I<sub>ZT</sub> or I<sub>ZK</sub>. Zener impedance is measured at two points to insure a sharp knee on the breakdown curve and eliminate unstable units.
- 3: The reverse surge current is measured at 25°C ambient using a 1/2 square wave or equivalent sine wave pulse 1/120 second duration superimposed on I<sub>ZT</sub>.
- 4: Voltage measurements to be performed 90 seconds after application of DC current.
- 5: RoHs Compliant already and Pb-free sticker on reel , box & carton indicated RoHs compliant .

# 1N4729AW thru 1N4761AW

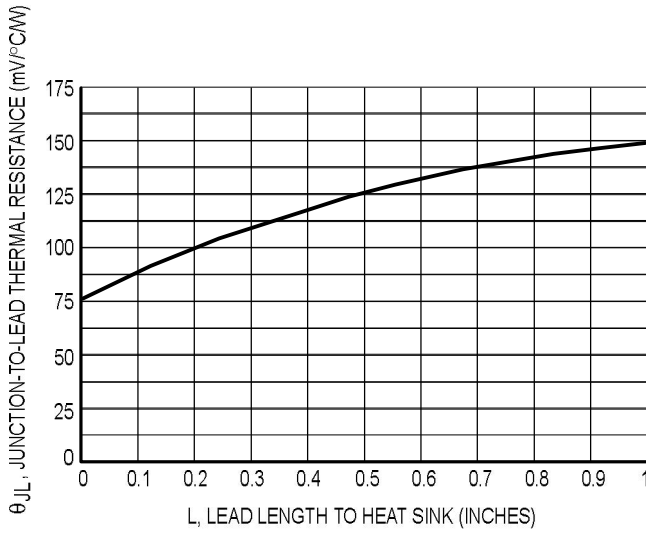

**Figure 1. Typical Thermal Resistance versus Lead Length**

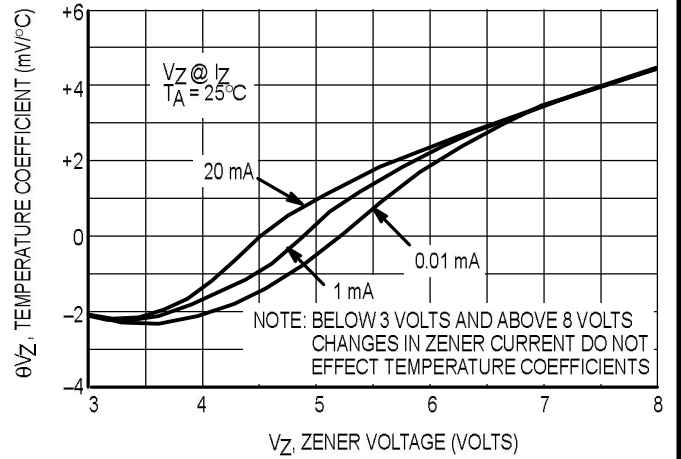

**Figure 2. Effect of Zener Current**

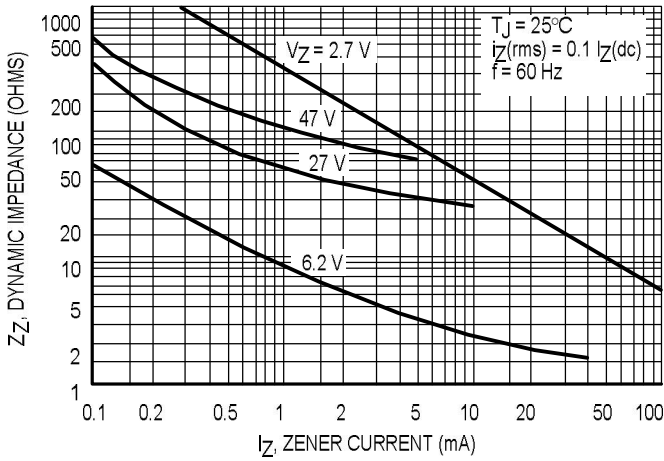

**Figure 3. Effect of Zener Current on Zener Impedance**

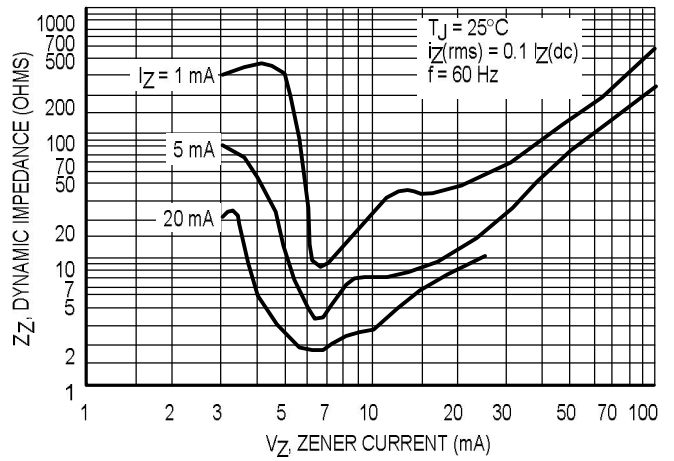

**Figure 4. Effect of Zener Voltage on Zener Impedance**