



DONGGUAN NANJING ELECTRONICS LTD.,
TO-92 Plastic-Encapsulate Transistors

2N5551 TRANSISTOR (NPN)

FEATURES

- General Purpose Switching Application

MAXIMUM RATINGS (T_a=25°C unless otherwise noted)

Symbol	Parameter	Value	Unit
V _{CB0}	Collector-Base Voltage	180	V
V _{CEO}	Collector-Emitter Voltage	160	V
V _{EBO}	Emitter-Base Voltage	6	V
I _C	Collector Current	0.6	A
P _C	Collector Power Dissipation	625	mW
R _{θJA}	Thermal Resistance From Junction To Ambient	200	°C/W
T _j	Junction Temperature	150	°C
T _{stg}	Storage Temperature	-55~+150	°C

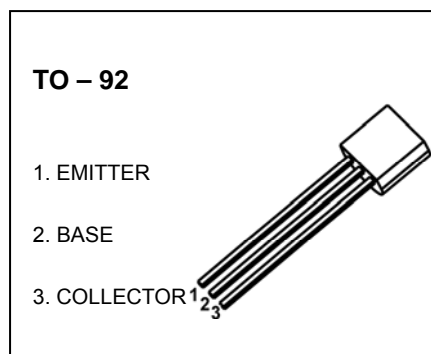

ELECTRICAL CHARACTERISTICS (T_a=25°C unless otherwise specified)

Parameter	Symbol	Test conditions	Min	Typ	Max	Unit
Collector-base breakdown voltage	V _{(BR)CBO}	I _C =100μA, I _E =0	180			V
Collector-emitter breakdown voltage	V _{(BR)CEO} *	I _C =1mA, I _B =0	160			V
Emitter-base breakdown voltage	V _{(BR)EBO}	I _E =10μA, I _C =0	6			V
Collector cut-off current	I _{CBO}	V _{CB} =120V, I _E =0			50	nA
Emitter cut-off current	I _{EBO}	V _{EB} =4V, I _C =0			50	nA
DC current gain	h _{FE(1)}	V _{CE} =5V, I _C =1mA	80			
	h _{FE(2)}	V _{CE} =5V, I _C =10mA	80		300	
	h _{FE(3)}	V _{CE} =5V, I _C =50mA	50			
Collector-emitter saturation voltage	V _{CE(sat) (1)}	I _C =10mA, I _B =1mA			0.15	V
	V _{CE(sat) (2)}	I _C =50mA, I _B =5mA			0.2	V
Base-emitter saturation voltage	V _{BE (sat) (1)}	I _C =10mA, I _B =1mA			1	V
	V _{BE (sat) (2)}	I _C =50mA, I _B =5mA			1	V
Collector output capacitance	C _{ob}	V _{CB} =10V, I _E =0, f=1MHz			6	pF
Emitter input capacitance	C _{ib}	V _{BE} =0.5V, I _C =0, f=1MHz			20	pF
Transition frequency	f _T	V _{CE} =10V, I _C =10mA, f=100MHz	100		300	MHz

*Pulse test: pulse width ≤300μs, duty cycles ≤ 2.0%.

CLASSIFICATION OF h_{FE(2)}

RANK		A	B	C
RANGE	80-100	100-150	150-200	200-300

Typical Characteristics

2N5551

