



DONGGUAN NANJING ELECTRONICS LTD.,
SOT-89-3L Plastic-Encapsulate Transistors

A44 TRANSISTOR (NPN)

FEATURES

- Low Collector-Emitter Saturation Voltage
- High Breakdown Voltage

MARKING: A44

MAXIMUM RATINGS ($T_a=25^{\circ}\text{C}$ unless otherwise noted)

Symbol	Parameter	Value	Unit
V_{CB0}	Collector-Base Voltage	500	V
V_{CE0}	Collector-Emitter Voltage	400	V
V_{EBO}	Emitter-Base Voltage	6	V
I_C	Collector Current -Continuous	200	mA
I_{CM}	Collector Current -Pulsed	300	mA
P_C	Collector Power Dissipation	500	mW
$R_{\theta JA}$	Thermal Resistance from Junction to Ambient	250	$^{\circ}\text{C}/\text{W}$
T_j	Junction Temperature	150	$^{\circ}\text{C}$
T_{stg}	Storage Temperature	-55~+150	$^{\circ}\text{C}$

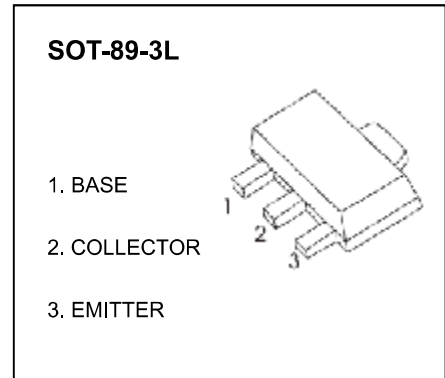

ELECTRICAL CHARACTERISTICS ($T_a=25^{\circ}\text{C}$ unless otherwise specified)

Parameter	Symbol	Test conditions	Min	Typ	Max	Unit
Collector-base breakdown voltage	$V_{(BR)CBO}$	$I_C=100\mu\text{A}, I_E=0$	500			V
Collector-emitter breakdown voltage	$V_{(BR)CEO}^*$	$I_C=1\text{mA}, I_B=0$	400			V
Emitter-base breakdown voltage	$V_{(BR)EBO}$	$I_E=10\mu\text{A}, I_C=0$	6			V
Collector cut-off current	I_{CBO}	$V_{CB}=400\text{V}, I_E=0$			0.1	μA
Emitter cut-off current	I_{EBO}	$V_{EB}=4\text{V}, I_C=0$			0.1	μA
DC current gain	$h_{FE(1)}^*$	$V_{CE}=10\text{V}, I_C=1\text{mA}$	40			
	$h_{FE(2)}^*$	$V_{CE}=10\text{V}, I_C=10\text{mA}$	50		200	
	$h_{FE(3)}^*$	$V_{CE}=10\text{V}, I_C=50\text{mA}$	45			
	$h_{FE(4)}^*$	$V_{CE}=10\text{V}, I_C=100\text{mA}$	40			
Collector-emitter saturation voltage	$V_{CE(sat)}^*$	$I_C=1\text{mA}, I_B=0.1\text{mA}$			0.4	V
		$I_C=10\text{mA}, I_B=1\text{mA}$			0.5	V
		$I_C=50\text{mA}, I_B=5\text{mA}$			0.75	V
Base-emitter saturation voltage	$V_{BE(sat)}^*$	$I_C=10\text{mA}, I_B=1\text{mA}$			0.75	V
Collector output capacitance	C_{ob}	$V_{CB}=20\text{V}, I_E=0, f=1\text{MHz}$			7	pF
Emitter input capacitance	C_{ib}	$V_{BE}=0.5\text{V}, I_C=0, f=1\text{MHz}$			130	pF

*Pulse test: pulse width $\leq 300\mu\text{s}$, duty cycles $\leq 2.0\%$.