



Description

■ This device is an ultra low capacitance PESD product designed to protect very high speed data interfaces. ESDPSA0603V05 has a typical capacitance of only 0.05pf (I/O to GND), and it can be used to meet the ESD immunity requirements of IEC61000-4-2 (15KV air, 8KV contact discharge).

Feature

- ESD protection for high speed data lines to IEC61000-4-2
- ESD contact discharge typical 8KV, max 15KV
- ESD air discharge typical 15KV, max 25KV
- Surface mount
- Extremely low capacitance
- Very low leakage current
- Fast response time
- Bi-directional ESD protection
- Lead free solder termination
- The best ESD protection for high frequency, low voltage applications

ESDPSA0603V05

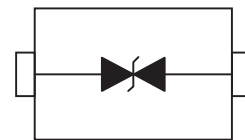
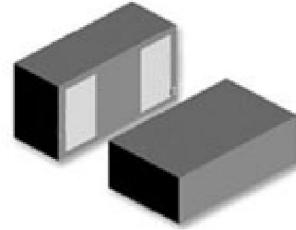

Schematic Diagram

Application

- High Definition Multi-Media Interface (HDMI)
- Digital Visual Interface (DVI)
- Display Port Interface (DP)
- Unified Display Interface (UDI)
- Mobile Display Digital Interface (MDDI)
- Gigabit Ethernet
- USB2.0 and USB3.0
- IEEE1394 interface

Caution:

This component is designed for signal line protection only, Not intended to be used under bias, not for application with a power line.



Absolute Maximum Ratings

| Parameter | Symbol | Value | Unit |
|--|-------------------|-------------|------|
| Maximum Contact discharge voltage Per IEC61000-4-2 | --- | 15KV | V |
| Maximum Air discharge voltage Per IEC61000-4-2 | --- | 25KV | V |
| Maximum Operating temperature | T _{OPER} | -40 to +90 | °C |
| Maximum Storage temperature | T _{STG} | -55 to +125 | °C |
| Maximum lead temperature for soldering during 10s | T _L | 260 | °C |

Electrical Characteristics(T_A=25°C)

| Parameter | Symbol | Test Conditions | Min | Typ | Max | Units |
|------------------|----------------|-------------------------------------|-----|------|------|-------|
| Rated Voltage | V _R | --- | --- | --- | 5 | V |
| Trigger voltage | V _T | IEC61000-4-2 8KV contact discharge | --- | 350 | --- | V |
| Clamping voltage | V _C | IEC61000-4-2 8KV contact discharge | --- | 35 | --- | V |
| Leakage current | I _L | DC 5V shall be applied on component | --- | | 0.10 | uA |
| Capacitance | C _P | V _R = 0V, f = 1MHz | --- | 0.05 | | pF |

Note: 1 Trigger and clamping voltage are measured per IEC 61000-4-2, 8KV contact discharge method.

2 After reliability tests such as high temp storage, temp cycles, continuous ESD strike etc, the maximum leakage current is less than 10uA.

ESD Clamping Test

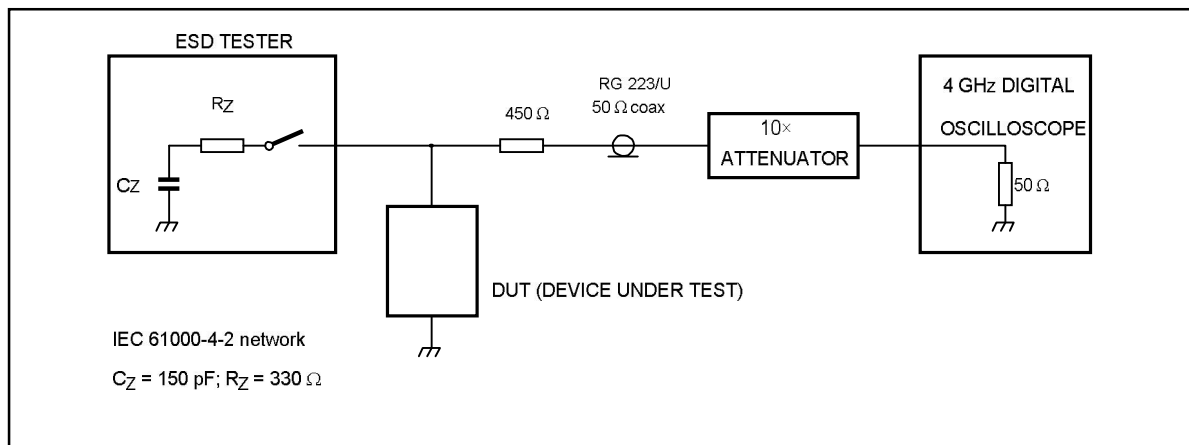



ESD Clamping Test Waveforms

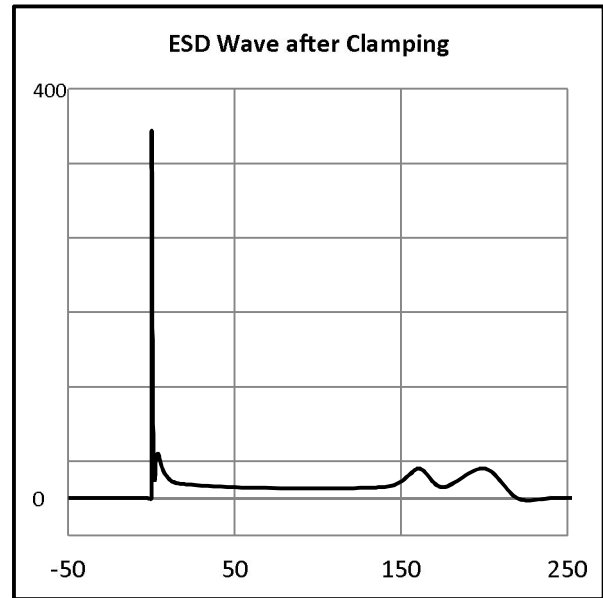
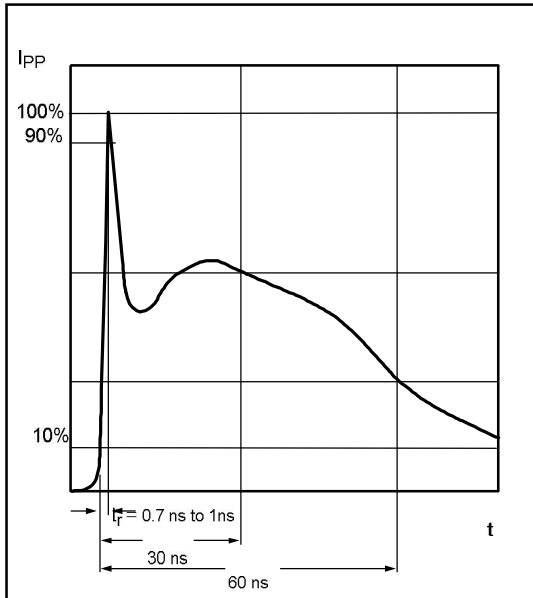

Product Dimension

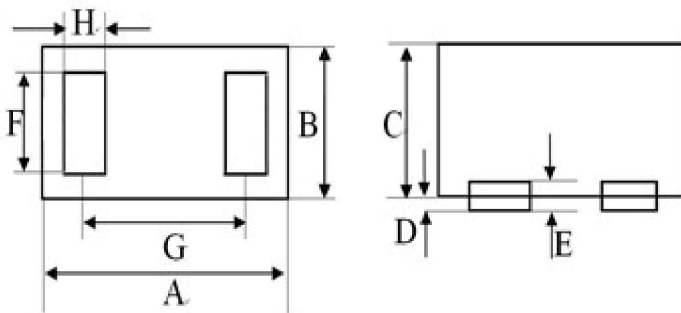

| Dim | millimeters | |
|-----|-------------|------|
| | min | max |
| A | 1.45 | 1.75 |
| B | 0.70 | 0.95 |
| C | 0.43 | 0.63 |
| D | 0.00 | 0.05 |
| E | 0.125REF | |
| F | 0.70 | 0.80 |
| G | 1.30BSC | |
| H | 0.45 | 0.55 |

PAD Dimension

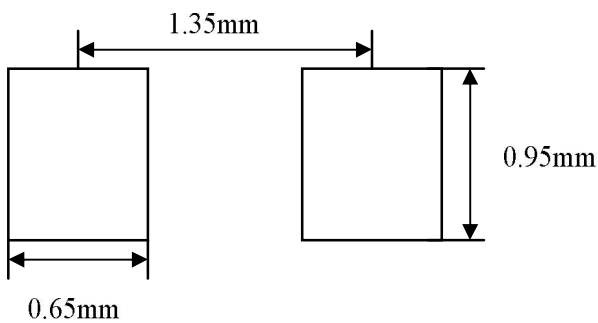

Solder thickness 0.15 to 0.2mm



Solder Reflow Recommendations

Temperatures (°C)

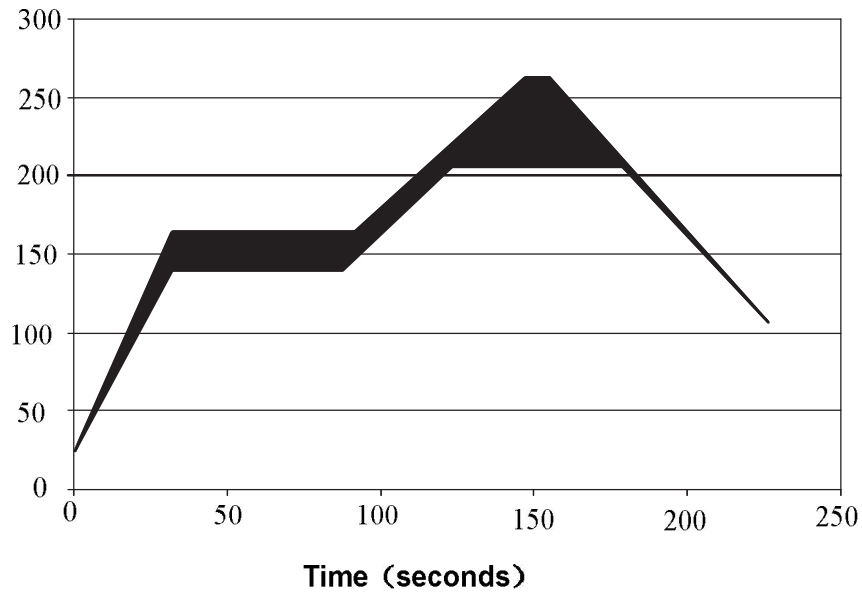

Package Information

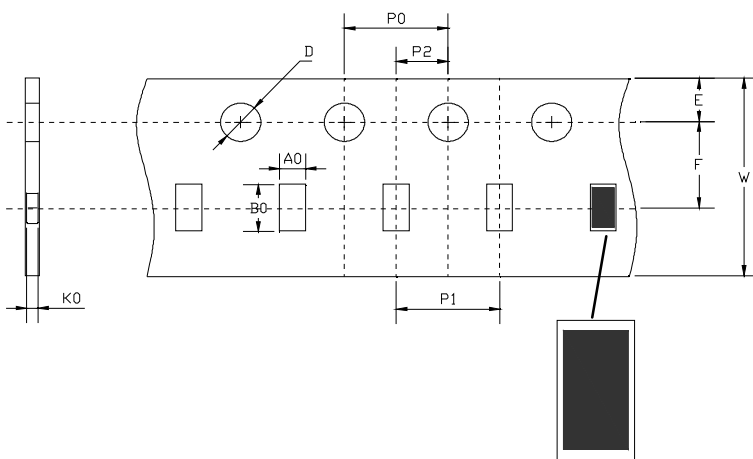

| Dimension | Typical | Unit |
|-----------|---------|------|
| A0 | 1.10 | mm |
| B0 | 1.90 | |
| K0 | 0.60 | |
| D | 1.55 | |
| P0 | 4.00 | |
| P1 | 4.00 | |
| P2 | 2.00 | |
| E | 1.75 | |
| F | 3.50 | |
| W | 8.00 | |

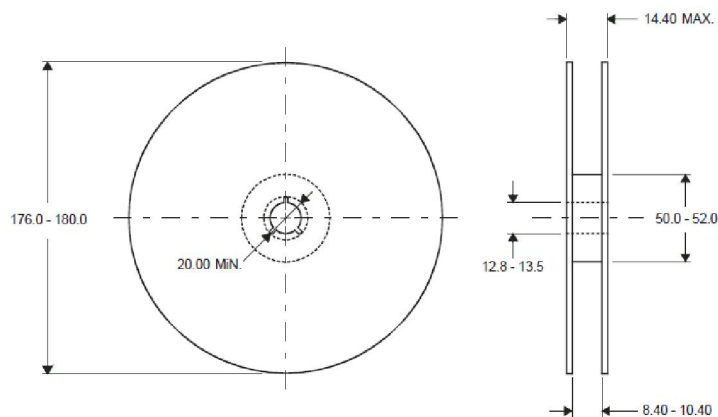

DIMENSIONS ARE: MILLIMETERS



Part Number System

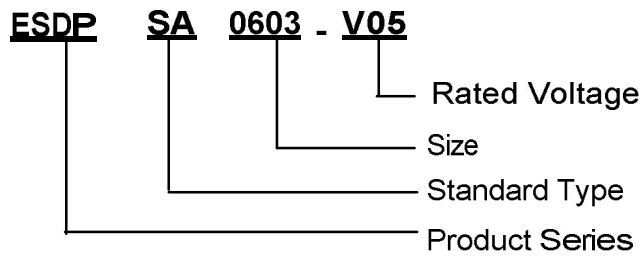

Order Information

| Device | Package | Net Weight | Carrier | Quantity | HSF Status |
|---------------|---------|------------|-------------|---------------|----------------|
| ESDPSA0603V05 | 0603 | 0.9 mg | Tape & Reel | 5,000pcs/reel | RoHS compliant |

Revision history

| Date | Revision | Description of changes |
|------------|----------|---------------------------|
| 1-Mar-2013 | 3.0 | Change Dimensions, Low Vt |