



## Description

■ This device is an ultra low capacitance ESD product designed to protect very high speed data interfaces. ESDCSA0402V05 has a typical capacitance of only 0.15pf (I/O to GND), and it can be used to meet the ESD immunity requirements of IEC61000-4-2 (15KV air, 8KV contact discharge).

## Feature

- ESD protection for high speed data lines to IEC61000-4-2
- ESD contact discharge typical 8KV, max 15KV
- ESD air discharge typical 15KV, max 25KV
- Surface mount
- Extremely low capacitance
- Very low leakage current
- Fast response time
- Bi-directional ESD protection
- Lead free solder termination
- The best ESD protection for high frequency, low voltage applications

## ESDCSA0402V05

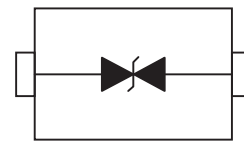
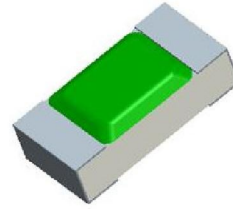

Schematic Diagram

## Application

- High Definition Multi-Media Interface (HDMI)
- Digital Visual Interface (DVI)
- Display Port Interface (DP)
- Unified Display Interface (UDI)
- Mobile Display Digital Interface (MDDI)
- Gigabit Ethernet
- USB2.0 and USB3.0
- IEEE1394 interface

### Caution:

This component is designed for signal line protection only,  
Not intended to be used under bias, not for application with a power line.



## Absolute Maximum Ratings

Parameter	Symbol	Value	Unit
Maximum Contact discharge voltage Per IEC61000-4-2	---	15KV	V
Maximum Air discharge voltage Per IEC61000-4-2	---	25KV	V
Maximum Operating temperature	T <sub>OPER</sub>	-40 to +90	°C
Maximum Storage temperature	T <sub>STG</sub>	-55 to +125	°C
Maximum lead temperature for soldering during 10s	T <sub>L</sub>	260	°C

## Electrical Characteristics(T<sub>A</sub>=25°C)

Parameter	Symbol	Test Conditions	Min	Typ	Max	Units
Rated Voltage	V <sub>R</sub>	---	---	---	5	V
Trigger voltage	V <sub>T</sub>	IEC61000-4-2 8KV contact discharge	---	350	---	V
Clamping voltage	V <sub>C</sub>	IEC61000-4-2 8KV contact discharge	---	35	---	V
Leakage current	I <sub>L</sub>	DC 5V shall be applied on component	---		0.10	uA
Capacitance	C <sub>P</sub>	V <sub>R</sub> = 0V, f = 1MHz	---	0.15		pF

Note: 1 Trigger and clamping voltage are measured per IEC 61000-4-2, 8KV contact discharge method.

2 After reliability tests such as high temp storage, temp cycles, continuous ESD strike etc, the maximum leakage current is less than 10uA.

## ESD Clamping Test

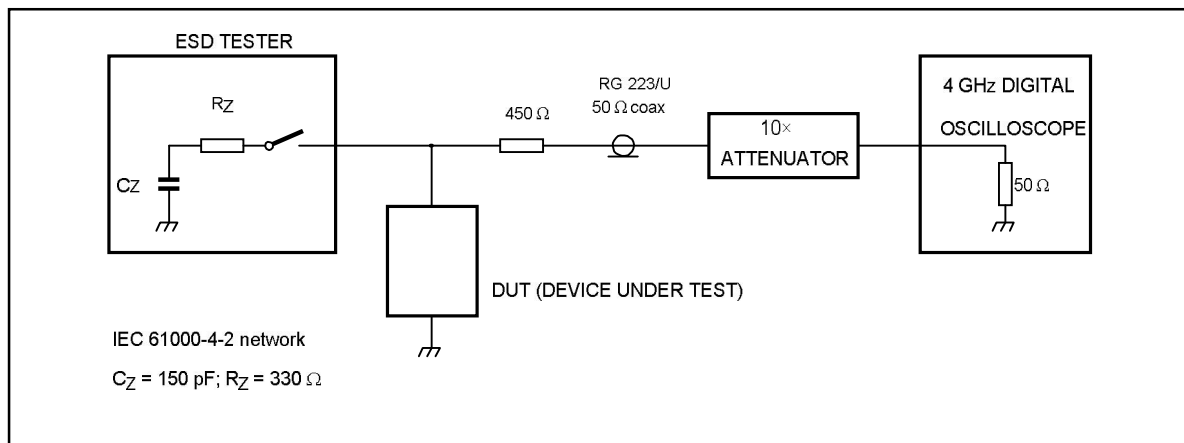



### ESD Clamping Test Waveforms

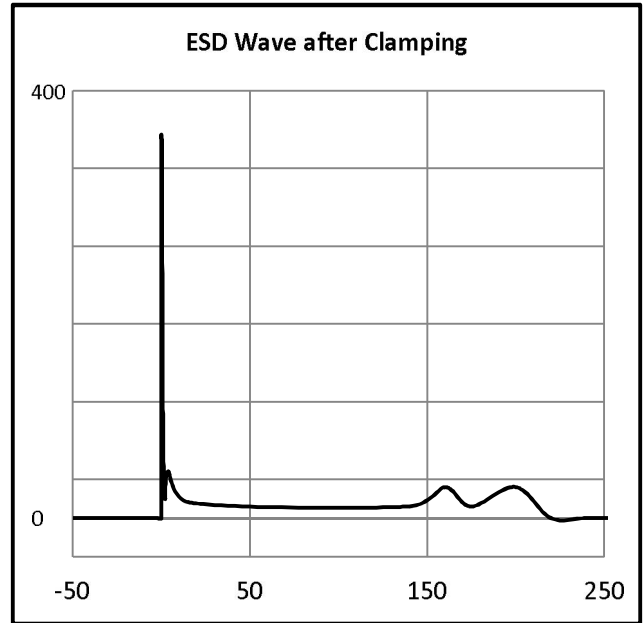
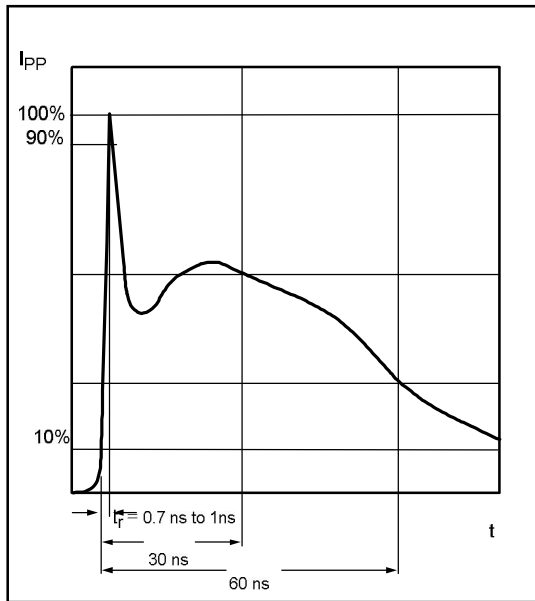

### Product Dimension

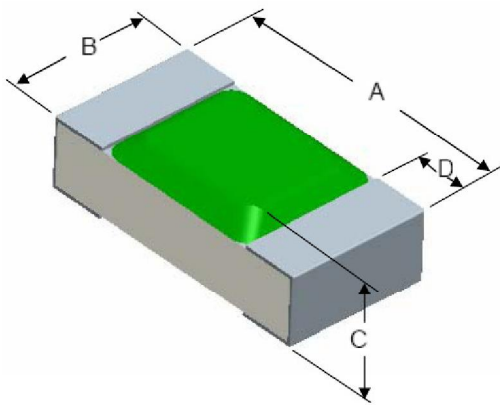

Parameter	Symbol	Dimension			Unit
		Min	Typ	Max	
Length	A	0.90	1.05	1.20	mm
Width	B	0.45	0.55	0.65	
Height	C	0.26	0.36	0.46	
*1Terminal width	D	0.15	0.25	0.35	

### PAD Dimension

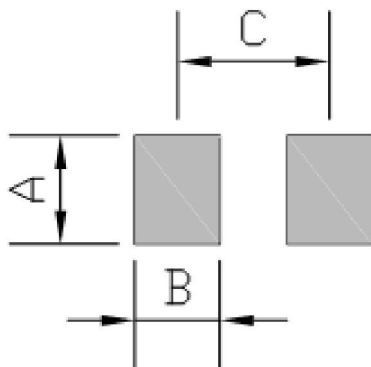

Symbol	Dimension	Unit
A	0.60	mm
B	0.50	
C	0.90	



### Solder Reflow Recommendations

Temperatures (°C)

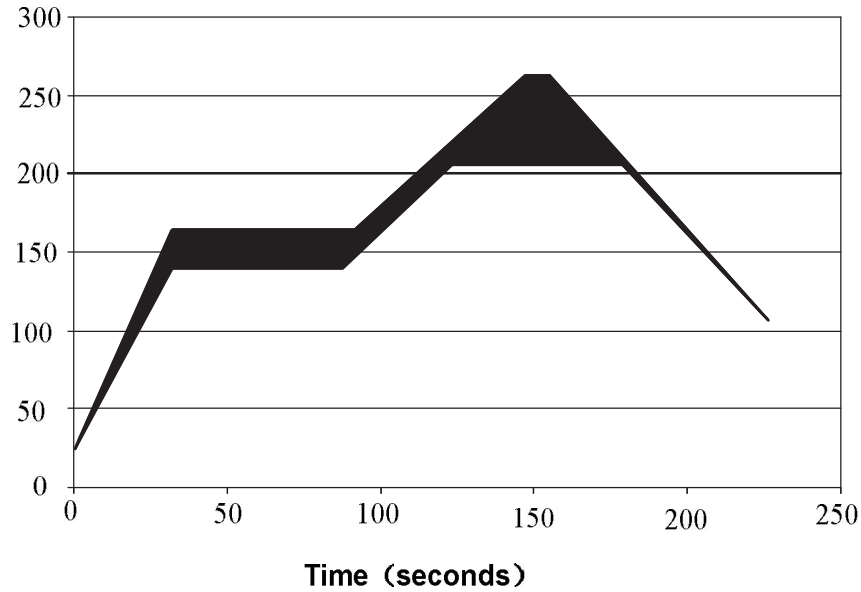

### Package Information

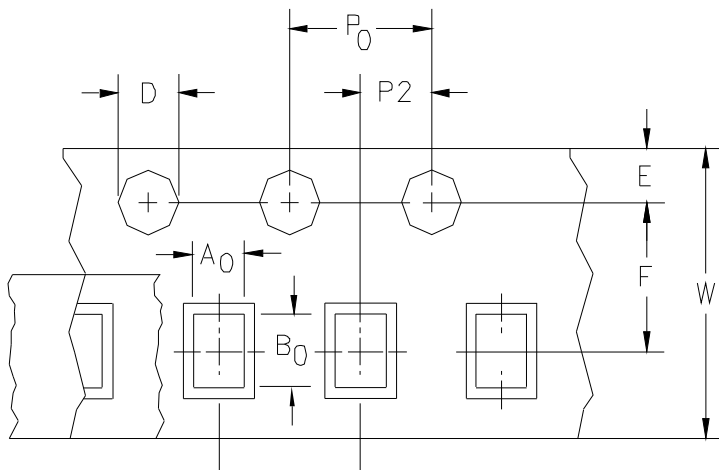

Dimension	Typical	Unit
A0	0.75	mm
B0	1.22	
D	1.55	
P0	4.00	
P1	2.00	
P2	2.00	
E	1.75	
F	3.50	
W	8.00	

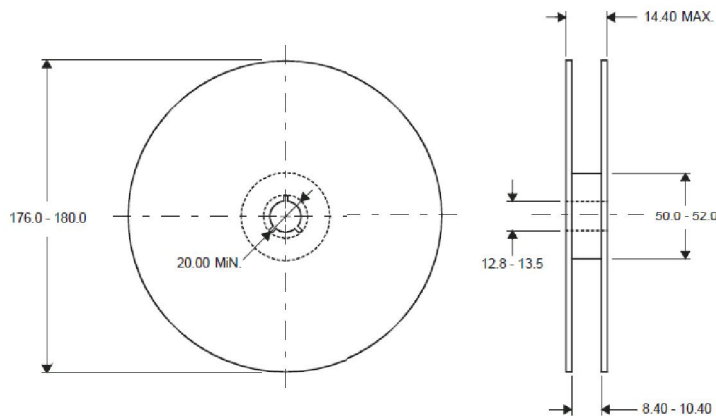

DIMENSIONS ARE: MILLIMETERS



### Part Number System

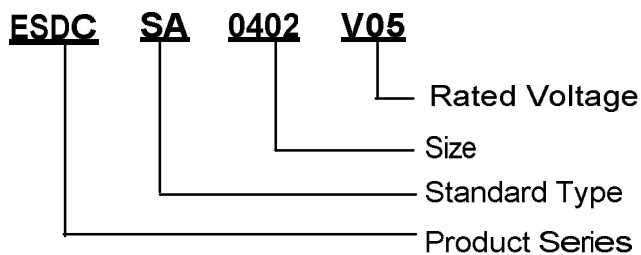

### Order Information

Device	Package	Net Weight	Carrier	Quantity	HSF Status
ESDCSA0402V05	0402	0.44 mg	Tape & Reel	10,000pcs/reel	RoHS compliant

### Revision history

Date	Revision	Description of changes
17-June-2012	2.0	Change P/N