

NJ1N60 POWER MOSFET

1.2A 600V N-CHANNEL POWER MOSFET



DESCRIPTION

The NJ **1N60** is a high voltage MOSFET and is designed to have better characteristics, such as fast switching time, low gate charge, low on-state resistance and have a high rugged avalanche characteristics. This power MOSFET is usually used at high speed switching applications in power supplies, PWM motor controls, high efficient DC to DC converters and bridge circuits.

FEATURES

- * $V_{DS} = 600V$
- * $I_D = 1.2A$
- * $R_{DS(ON)} = 11.5\Omega @ V_{GS} = 10V$.
- * Ultra Low gate charge (typical 5.0nC)
- * Low reverse transfer capacitance ($C_{RSS} =$ typical 3.0 pF)
- * Fast switching capability
- * Avalanche energy specified
- * Improved dv/dt capability, high ruggedness

SYMBOL

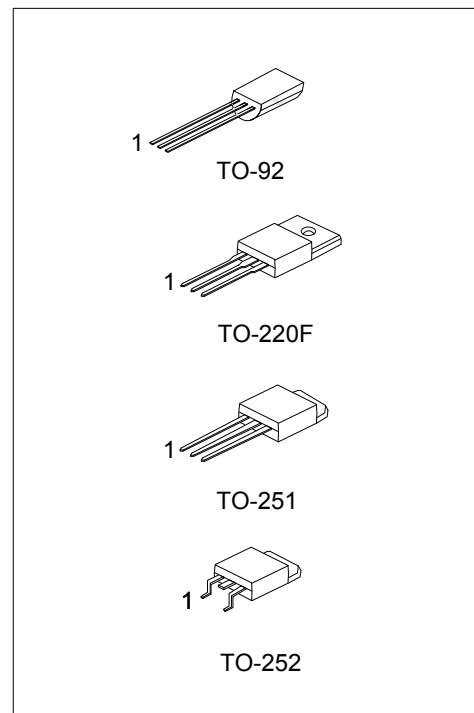
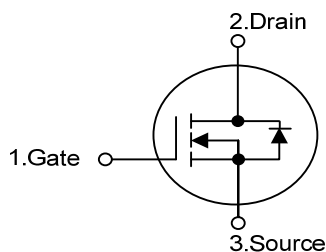

ORDERING INFORMATION

Ordering Number	Package	Pin Assignment			Packing
		1	2	3	
NJ1N60-TB	TO-92	G	D	S	Tape Box
NJ1N60-BL	TO-92	G	D	S	Bulk
NJ1N60F-LI	TO-220F	G	D	S	Tube
NJ1N60A-LI	TO-251	G	D	S	Tube
NJ1N60D-TR	TO-252	G	D	S	Tape Ree
NJ1N60D-LI	TO-252	G	D	S	Tube

Note: Pin Assignment: G: Gate D: Drain S: Source

NJ1N60 POWER MOSFET

■ ABSOLUTE MAXIMUM RATINGS ($T_C = 25^\circ\text{C}$, unless otherwise specified)

PARAMETER		SYMBOL	RATINGS	UNIT
Drain-Source Voltage		V_{DSS}	600	V
Gate-Source Voltage		V_{GSS}	± 30	V
Avalanche Current (Note 2)		I_{AR}	1.2	A
Continuous Drain Current		I_D	1.2	A
Pulsed Drain Current (Note 2)		I_{DM}	4.8	A
Avalanche Energy	Single Pulsed (Note 3)	E_{AS}	50	mJ
	Repetitive (Note 2)	E_{AR}	4.0	mJ
Peak Diode Recovery dv/dt (Note 4)		dv/dt	4.5	V/ns
Power Dissipation	TO-251/ TO-252	P_D	28	W
	TO-220F		21	W
	TO-92($T_a=25^\circ\text{C}$)		1	W
Junction Temperature		T_J	+150	$^\circ\text{C}$
Operating Temperature		T_{OPR}	-55 ~ +150	$^\circ\text{C}$
Storage Temperature		T_{STG}	-55 ~ +150	$^\circ\text{C}$

Notes: 1. Absolute maximum ratings are those values beyond which the device could be permanently damaged.

Absolute maximum ratings are stress ratings only and functional device operation is not implied.

2. Repetitive Rating: Pulse width limited by maximum junction temperature

3. $L = 60\text{mH}$, $I_{AS} = 1\text{A}$, $V_{DD} = 50\text{V}$, $R_G = 25\Omega$, Starting $T_J = 25^\circ\text{C}$

4. $I_{SD} \leq 1.2\text{A}$, $di/dt \leq 200\text{A}/\mu\text{s}$, $V_{DD} \leq BV_{DSS}$, Starting $T_J = 25^\circ\text{C}$

■ THERMAL DATA

PARAMETER		SYMBOL	RATINGS	UNIT
Junction to Ambient	TO-251/ TO-252	θ_{JA}	110	$^\circ\text{C}/\text{W}$
	TO-220F		62.5	
	TO-92		140	
Junction to Case	TO-251/ TO-252	θ_{Jc}	4.53	$^\circ\text{C}/\text{W}$
	TO-220F		5.95	

NJ1N60 POWER MOSFET

■ ELECTRICAL CHARACTERISTICS (T_C=25°C, unless otherwise specified.)

PARAMETER	SYMBOL	TEST CONDITIONS	MIN	TYP	MAX	UNIT
OFF CHARACTERISTICS						
Drain-Source Breakdown Voltage	BV _{DSS}	V _{GS} =0V, I _D =250μA	600			V
Drain-Source Leakage Current	I _{DSS}	V _{DS} =600V, V _{GS} =0V			10	μA
Gate-Source Leakage Current	Forward	I _{GSS} V _{GS} =30V, V _{DS} =0V			100	nA
	Reverse		V _{GS} =-30V, V _{DS} =0V			-100
Breakdown Voltage Temperature Coefficient	ΔBV _{DSS} /ΔT _J	I _D =250μA		0.4		V/°C
ON CHARACTERISTICS						
Gate Threshold Voltage	V _{GS(TH)}	V _{DS} =V _{GS} , I _D =250μA	2.0		4.0	V
Static Drain-Source On-State Resistance	R _{DS(ON)}	V _{GS} =10V, I _D =0.6A		9.3	11.5	Ω
DYNAMIC CHARACTERISTICS						
Input Capacitance	C _{ISS}	V _{DS} =25V, V _{GS} =0V, f=1MHz		120	150	pF
Output Capacitance	C _{OSS}			20	25	pF
Reverse Transfer Capacitance	C _{RSS}			3.0	4.0	pF
SWITCHING CHARACTERISTICS						
Turn-On Delay Time	t _{D(ON)}	V _{DD} =300V, I _D =1.2A, R _G =50Ω (Note 2,3)		5	20	ns
Turn-On Rise Time	t _R			25	60	ns
Turn-Off Delay Time	t _{D(OFF)}			7	25	ns
Turn-Off Fall Time	t _F			25	60	ns
Total Gate Charge	Q _G	V _{DS} =480V, V _{GS} =10V, I _D =1.2A (Note 2,3)		5.0	6.0	nC
Gate-Source Charge	Q _{GS}			1.0		nC
Gate-Drain Charge	Q _{GD}			2.6		nC
SOURCE-DRAIN DIODE RATINGS AND CHARACTERISTICS						
Drain-Source Diode Forward Voltage	V _{SD}	V _{GS} =0V, I _S =1.2A			1.4	V
Maximum Continuous Drain-Source Diode Forward Current	I _S				1.2	A
Maximum Pulsed Drain-Source Diode Forward Current	I _{SM}				4.8	A
Reverse Recovery Time	t _{RR}	V _{GS} =0V, I _S =1.2A		160		ns
Reverse Recovery Charge	Q _{RR}	di _F /dt=100A/μs (Note 1)		0.3		μC

- Note: 1. Repetitive Rating: Pulse width limited by maximum junction temperature
 2. Pulse Test: Pulse Width ≤300μs, Duty Cycle≤2%
 3. Essentially Independent of Operating Temperature

NJ1N60 POWER MOSFET

TEST CIRCUITS AND WAVEFORMS

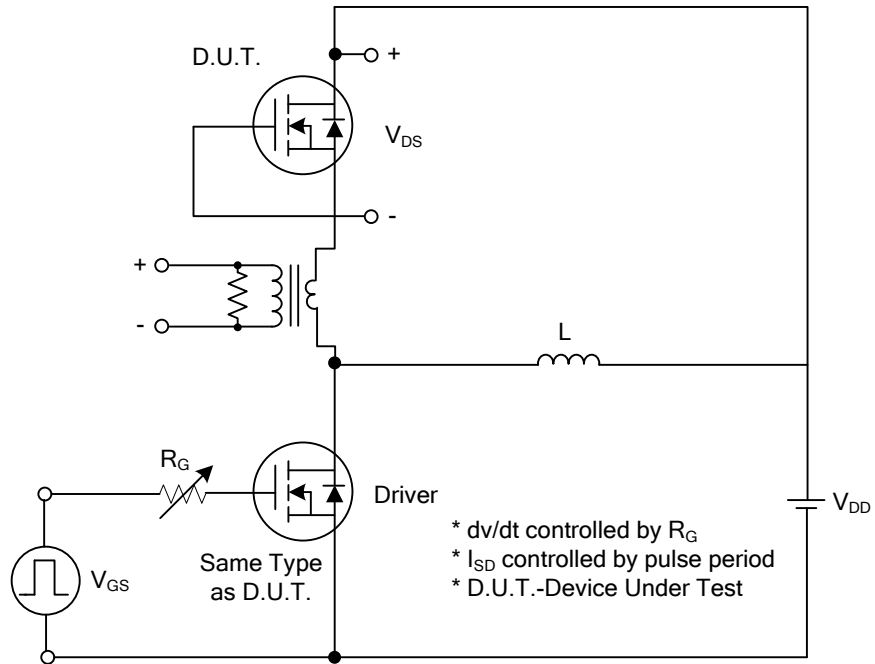

Peak Diode Recovery dv/dt Test Circuit

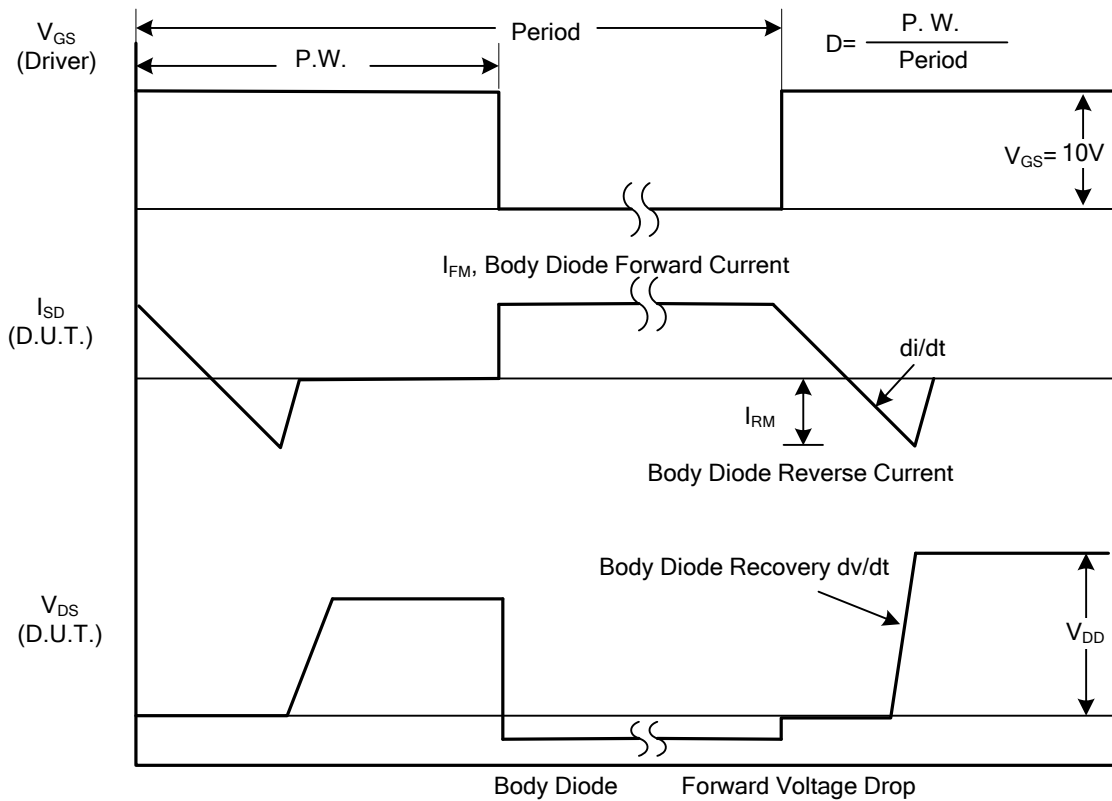

Peak Diode Recovery dv/dt Waveforms

NJ1N60 POWER MOSFET

TEST CIRCUITS AND WAVEFORMS (Cont.)

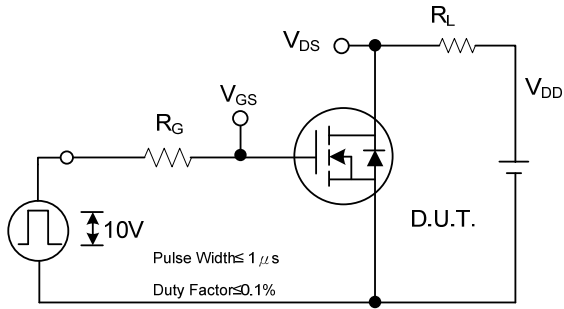

Switching Test Circuit

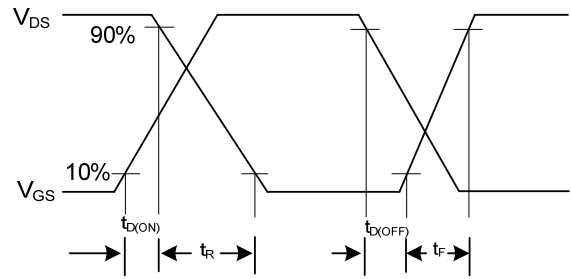

Switching Waveforms

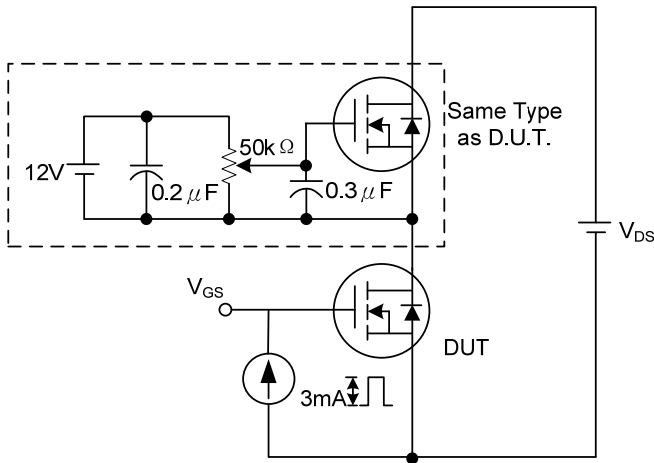

Gate Charge Test Circuit

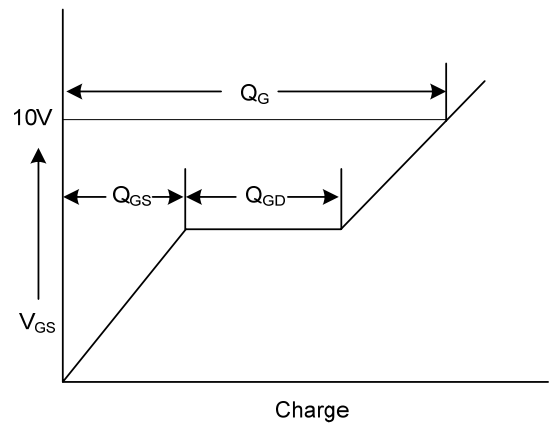

Gate Charge Waveform

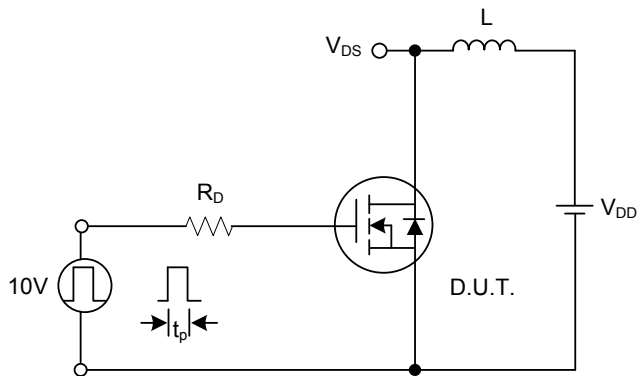

Unclamped Inductive Switching Test Circuit

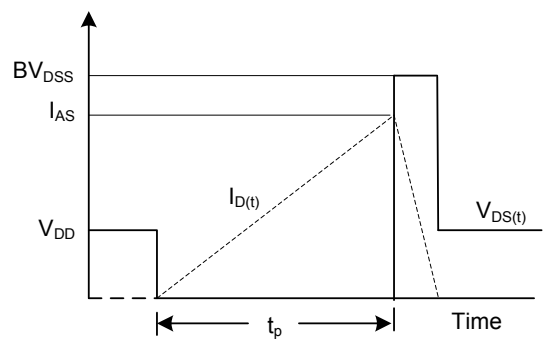

Unclamped Inductive Switching Waveforms

NJ1N60 POWER MOSFET

■ TYPICAL CHARACTERISTICS

