

NJ8N60 POWER MOSFET

7.5A 600V N-CHANNEL POWER MOSFET



DESCRIPTION

The NJ8N60 is a high voltage and high current power MOSFET, designed to have better characteristics, such as fast switching time, low gate charge, low on-state resistance and have a high rugged avalanche characteristics. This power MOSFET is usually used at high speed switching applications in power supplies, PWM motor controls, high efficient DC to DC converters and bridge circuits.

FEATURES

- * $V_{DS} = 600V$
- * $I_D = 7.5A$
- * $R_{DS(ON)} = 1.2\Omega @ V_{GS} = 10V$.
- * Ultra Low gate charge (typical 28nC)
- * Low reverse transfer capacitance ($C_{RSS} =$ typical 12.0 pF)
- * Fast switching capability
- * Avalanche energy specified
- * Improved dv/dt capability, high ruggedness

SYMBOL

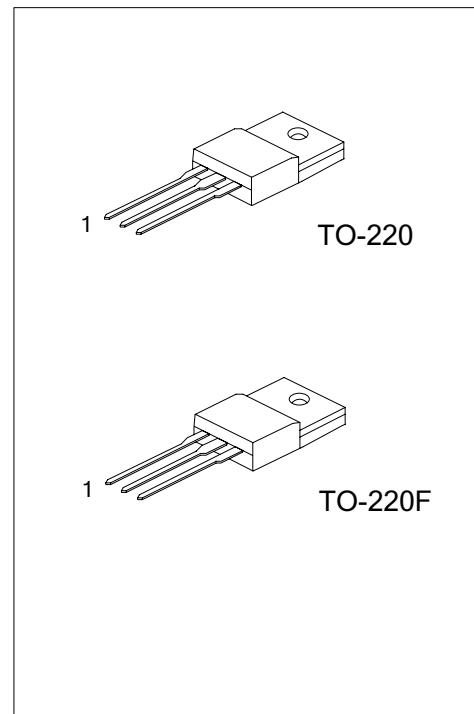
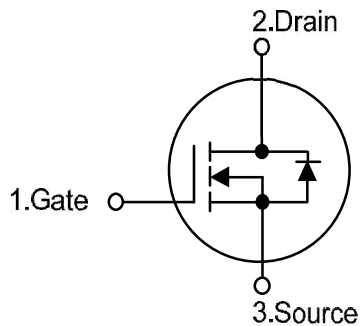

ORDERING INFORMATION

Ordering Number	Package	Pin Assignment			Packing
		1	2	3	
NJ8N60-LI	TO-220	G	D	S	Tape Box
NJ8N60-BL	TO-220	G	D	S	Bulk
NJ8N60F-LI	TO-220F	G	D	S	Tube

Note: Pin Assignment: G: Gate D: Drain S: Source

NJ8N60 POWER MOSFET

■ ABSOLUTE MAXIMUM RATINGS (T_C = 25°C, unless otherwise specified)

PARAMETER		SYMBOL	RATINGS	UNIT
Drain-Source Voltage		V _{DSS}	600	V
Gate-Source Voltage		V _{GSS}	±30	V
Avalanche Current (Note 2)		I _{AR}	7.5	A
Drain Current	Continuous	I _D	7.5	A
	Pulsed (Note 2)	I _{DM}	30	A
Avalanche Energy	Single Pulsed (Note 3)	E _{AS}	230	mJ
	Repetitive (Note 2)	E _{AR}	14.7	mJ
Peak Diode Recovery dv/dt (Note 4)		dv/dt	4.5	V/ns
Power Dissipation	TO-220	P _D	147	W
	TO-220F		48	W
Junction Temperature		T _J	+150	°C
Operating Temperature		T _{OPR}	-55 ~ +150	°C
Storage Temperature		T _{STG}	-55 ~ +150	°C

Notes: 1. Absolute maximum ratings are those values beyond which the device could be permanently damaged.

Absolute maximum ratings are stress ratings only and functional device operation is not implied.

2. Repetitive Rating : Pulse width limited by T_J

3. L = 7.3mH, I_{AS} = 7.5A, V_{DD} = 50V, R_G = 25 Ω, Starting T_J = 25°C

4. I_{SD} ≤ 7.5A, di/dt ≤ 200A/μs, V_{DD} ≤ BV_{DSS}, Starting T_J = 25°C

■ THERMAL DATA

PARAMETER		SYMBOL	RATING	UNIT
Junction to Ambient		θ _{JA}	62.5	°C/W
Junction to Case	TO-220	θ _{JC}	0.85	°C/W
	TO-220F		2.6	°C/W

NJ8N60 POWER MOSFET

■ ELECTRICAL CHARACTERISTICS (T_C = 25°C, unless otherwise specified)

PARAMETER	SYMBOL	TEST CONDITIONS	MIN	TYP	MAX	UNIT
OFF CHARACTERISTICS						
Drain-Source Breakdown Voltage	BV _{DSS}	V _{GS} = 0 V, I _D = 250 μA	600			V
Drain-Source Leakage Current	I _{DSS}	V _{DS} = 600 V, V _{GS} = 0 V			10	μA
Gate-Source Leakage Current	Forward	I _{GSS}			100	nA
	Reverse				-100	nA
Breakdown Voltage Temperature Coefficient	ΔBV _{DSS} /ΔT _J	I _D = 250 μA, Referenced to 25°C		0.7		V/°C
ON CHARACTERISTICS						
Gate Threshold Voltage	V _{GS(TH)}	V _{DS} = V _{GS} , I _D = 250 μA	2.0		4.0	V
Static Drain-Source On-State Resistance	R _{DS(ON)}	V _{GS} = 10 V, I _D = 3.75 A		1.0	1.2	Ω
DYNAMIC CHARACTERISTICS						
Input Capacitance	C _{ISS}	V _{DS} = 25 V, V _{GS} = 0 V, f = 1MHz		965	1255	pF
Output Capacitance	C _{OSS}			105	135	pF
Reverse Transfer Capacitance	C _{RSS}			12	16	pF
SWITCHING CHARACTERISTICS						
Turn-On Delay Time	t _{D(ON)}	V _{DD} = 300V, I _D = 7.5 A, R _G = 25Ω (Note 1, 2)		16.5	45	ns
Turn-On Rise Time	t _R			60.5	130	ns
Turn-Off Delay Time	t _{D(OFF)}			81	170	ns
Turn-Off Fall Time	t _F			64.5	140	ns
Total Gate Charge	Q _G	V _{DS} = 480V, I _D = 7.5A, V _{GS} = 10 V (Note 1, 2)		28	36	nC
Gate-Source Charge	Q _{GS}			4.5		nC
Gate-Drain Charge	Q _{GD}			12		nC
DRAIN-SOURCE DIODE CHARACTERISTICS AND MAXIMUM RATINGS						
Drain-Source Diode Forward Voltage	V _{SD}	V _{GS} = 0 V, I _S = 7.5 A			1.4	V
Maximum Continuous Drain-Source Diode Forward Current	I _S				7.5	A
Maximum Pulsed Drain-Source Diode Forward Current	I _{SM}				30	A
Reverse Recovery Time	t _{RR}	V _{GS} = 0 V, I _S = 7.5 A,		365		ns
Reverse Recovery Charge	Q _{RR}	dI _F /dt = 100 A/μs (Note 2)		3.4		μC

Notes: 1. Pulse Test: Pulse width ≤ 300μs, Duty cycle ≤ 2%

2. Essentially independent of operating temperature

NJ8N60 POWER MOSFET

■ TEST CIRCUITS AND WAVEFORMS

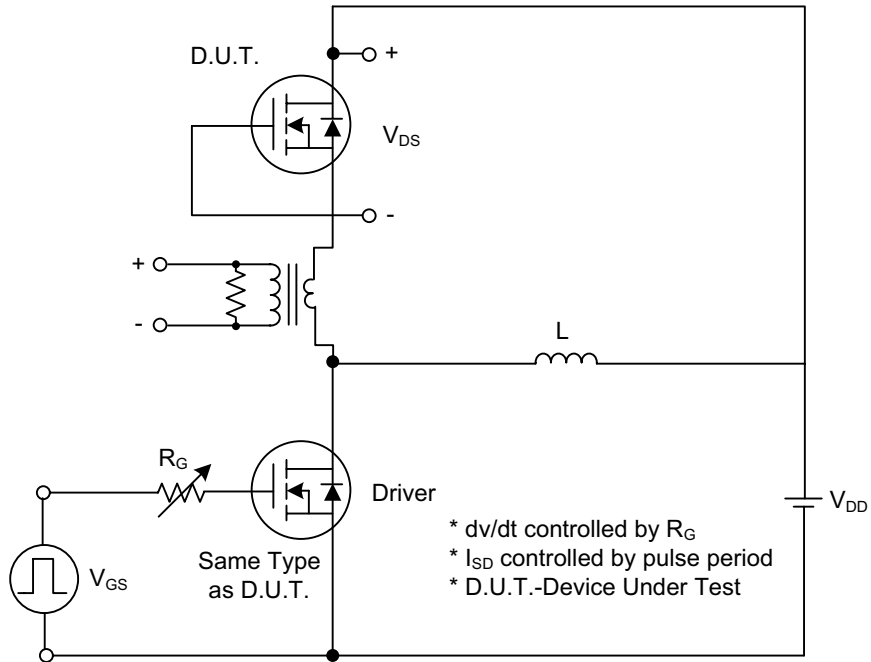

Peak Diode Recovery dv/dt Test Circuit

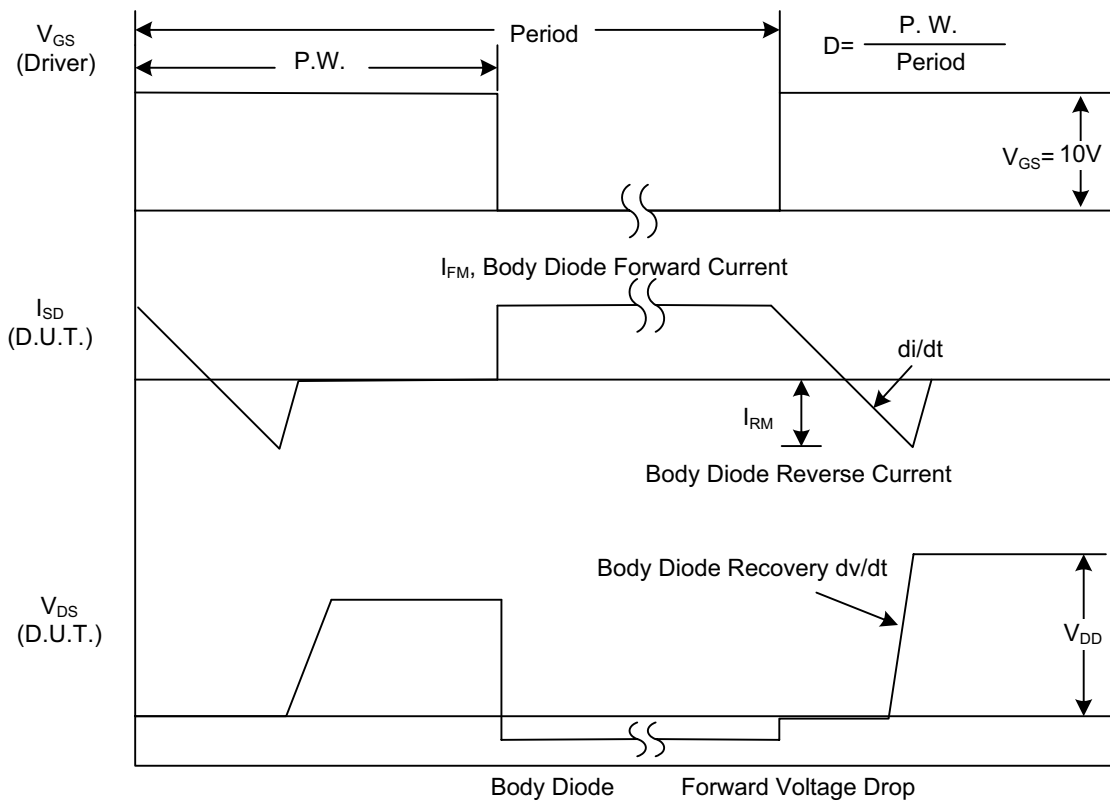

Peak Diode Recovery dv/dt Waveforms

NJ8N60 POWER MOSFET

■ TEST CIRCUITS AND WAVEFORMS (Cont.)

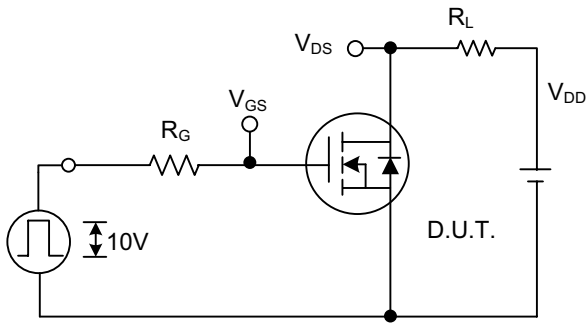

Switching Test Circuit

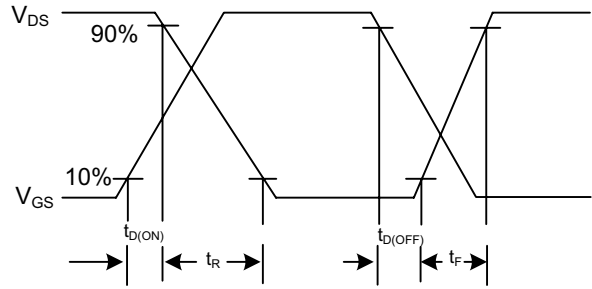

Switching Waveforms

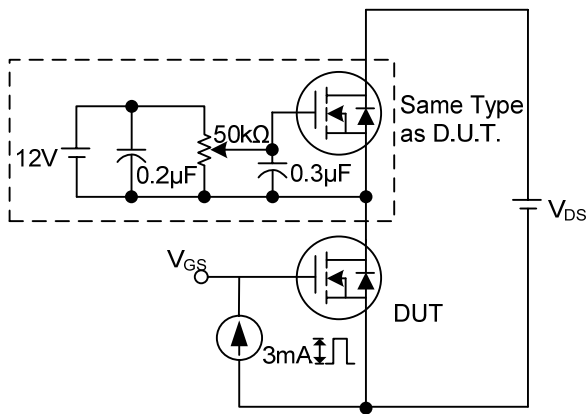

Gate Charge Test Circuit

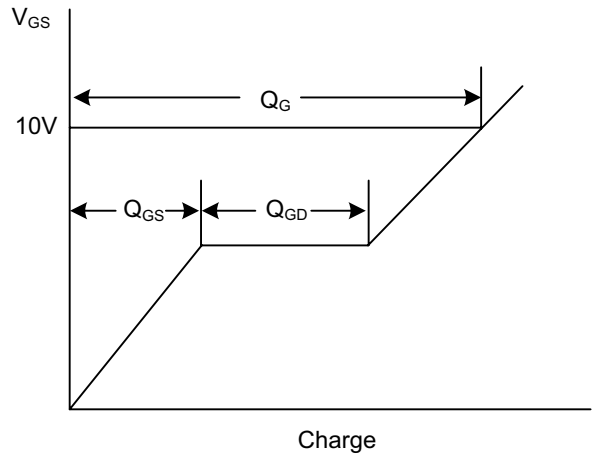

Gate Charge Waveform

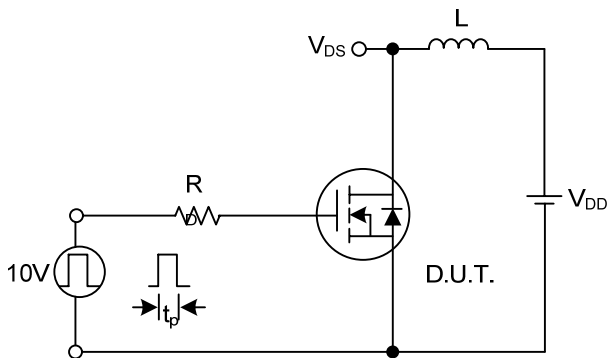

Unclamped Inductive Switching Test Circuit

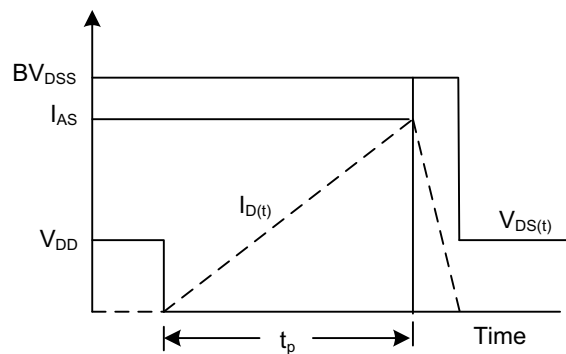

Unclamped Inductive Switching Waveforms

NJ8N60 POWER MOSFET

TYPICAL CHARACTERISTICS

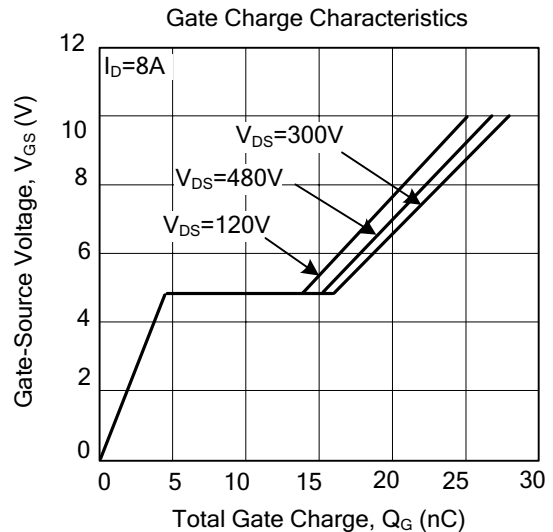
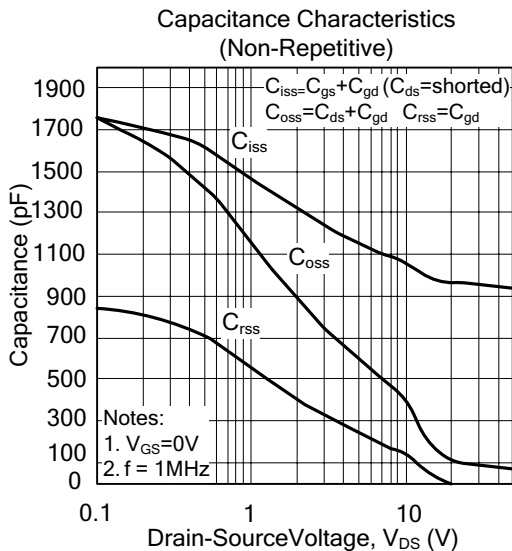
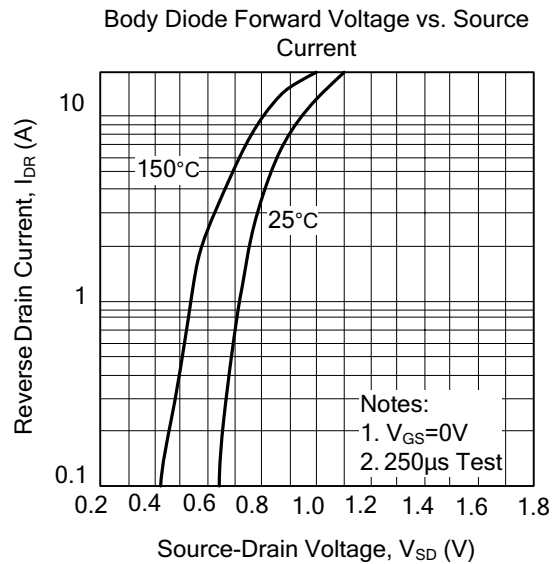
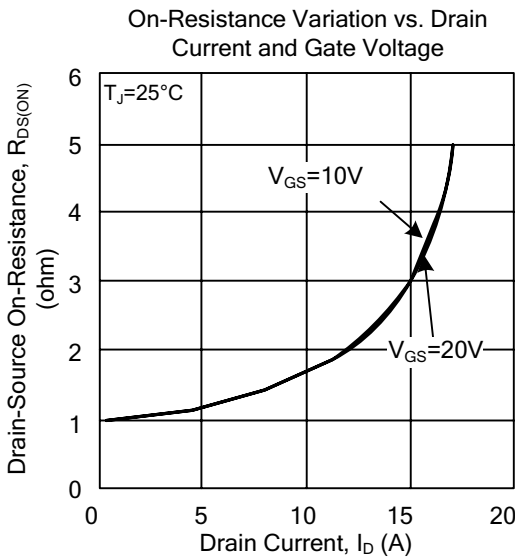
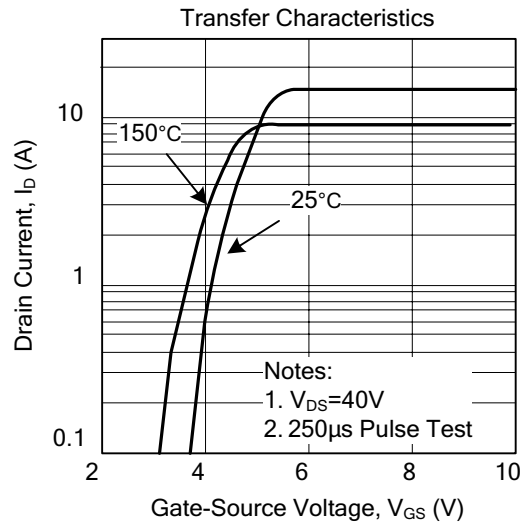
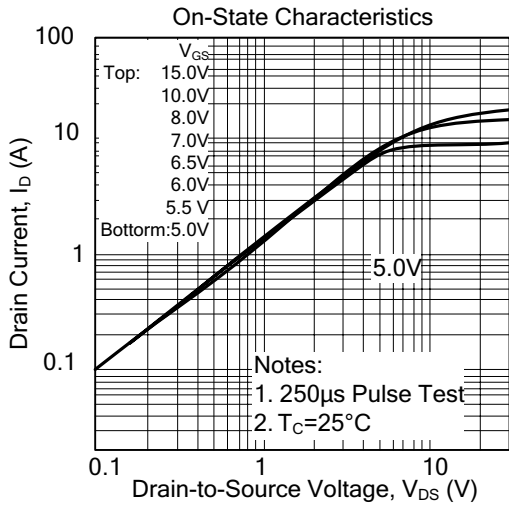

NJ8N60 POWER MOSFET

TYPICAL CHARACTERISTICS(Cont.)

