



14D Disc Varistor

FEATURES

- * Wide operating voltages ranging from 5Vrms to 1000Vrms (6Vdc to 1465Vdc).
- * Fast response time of less than 25nS, instantly clamping the transient over voltage.
- * High surge current handling capability.
- * High energy absorption capability.
- * Low clamping voltages, providing better surge protection
- * Low capacitance values, providing digital switching circuitry protection.
- * High insulation resistance, preventing electric arching to the adjacent devices or circuits.



APPLICATIONS

- * Transistor, Diode, IC, Thyristor or Triac semiconductor protection.
- * Surge protection in consumer electronics.
- * Surge protection in industrial electronics.
- * Surge protection in electronic home appliances, gas and petroleum appliances.
- * Relay and electromagnetic valve surge absorption.

General Characteristics Definition

- *Operating Temperature: -40 °C ~ +85 °C
- *Storage Temperature: -40 °C ~ +125 °C
- *Working Surface Temperature: +115 °C
- *Insulation Resistance: > 100M Ω
- *Coating (Epoxy Resin): Flame-Retardant to UL 94 V-0

Material

- *Coating: Epoxy Resin
- *Lead Wire: The Copper Wire
- *Electrode: Silver Solder
- *Disk: Zinc Oxide

Ordering Information

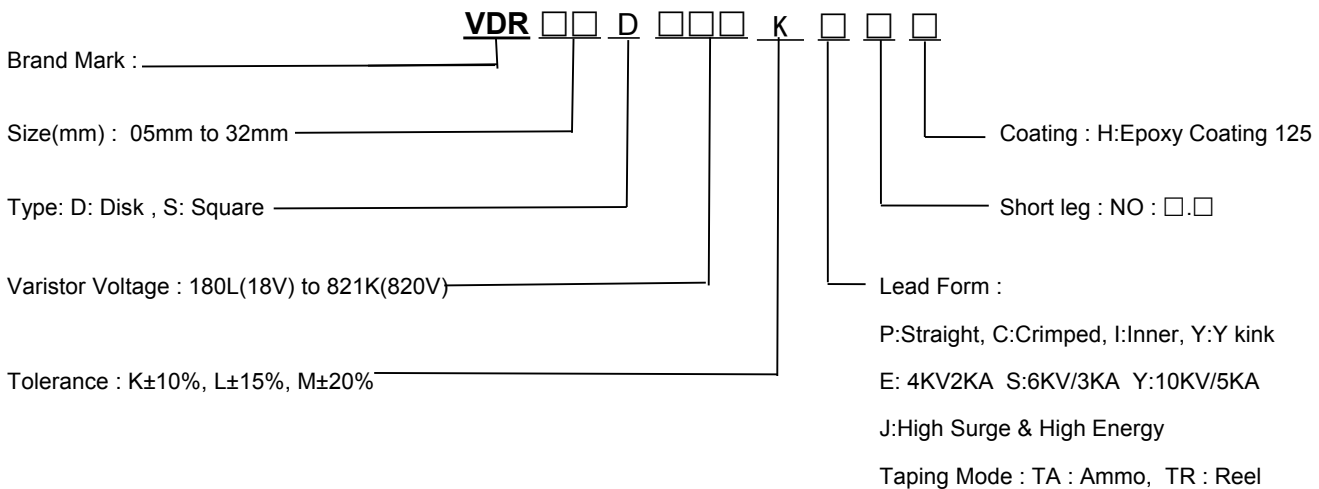

■ Dimensions

S Type(Straight Lead)

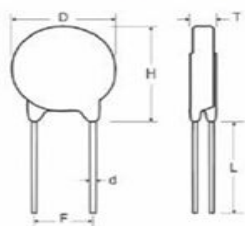

I Type(Inner Crimped Lead)

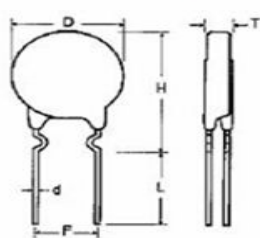

C Type(Out Crimped Lead)

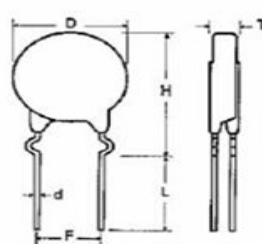

Y Lead Type(Y Kink Lead)

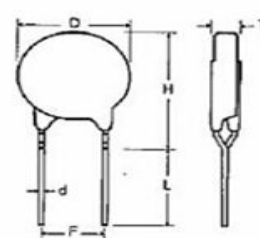



Unit: mm

Part No.	T Max.	D Max.	H Max.		L min.	F ±0.8	d ± 0.05
			SB	CB / IB / YB			
14D182K	12.5	17.0	18.0	21.0	20.0	7.5	0.8
14D152K	11.0						
14D112K	8.5						
14D102K	7.8						
14D911K	7.6						
14D821K	7.2						
14D781K	6.8						
14D751K	6.5						
14D681K	6.4						
14D621K	6.4						
14D561K	6.2						
14D511K	5.8						
14D471K	5.6						
14D431K	5.3						
14D391K	5.1						
14D361K	5.0						
14D331K	4.8						
14D301K	4.7						
14D271K	4.5						
14D241K	4.3						
14D221K	4.2						
14D201K	4.1						
14D181K	4.1						
14D151K	4.8						
14D121K	4.5						
14D101K	4.3						
14D820K	4.1						
14D680K	4.1						
14D560K	4.1						
14D470K	4.5						
14D390K	4.5						
14D330K	4.2						
14D270K	4.0						
14D220K	4.0						
14D180L	4.0						

14D Standard & High Surge

Part No.	Maximum Allowable Voltage		Energy 10/1000 μ S		Withstanding Surge Current 8/20 μ S				Rated POWER (W)	Varistor Voltage	Max Clamping Voltage	Capacitance
	ACrms	DC	Standard	High Surge	Standard (A)		High Surge(A)					
	(V)	(V)	(J)	(J)	1 TIME	2 TIME	1 TIME	2 TIME				
14D180L	10	14	6.6	7.0	1000	500	2000	1000	0.1	18(15-21)	38	11100
14D220K	14	18	7.6	8.0	1000	500	2000	1000	0.1	22(20-24)	43	9100
14D270K	17	22	9.7	10.0	1000	500	2000	1000	0.1	27(24-30)	53	7400
14D330K	20	26	12.3	12.5	1000	500	2000	1000	0.1	33(30-36)	65	6100
14D390K	25	31	13.2	13.0	1000	500	2000	1000	0.1	39(35-43)	77	5100
14D470K	30	38	16.8	17.0	1000	500	2000	1000	0.1	47(42-52)	93	4300
14D560K	35	45	19.6	20	1000	500	2000	1000	0.1	56(50-62)	110	3600
14D680K	40	56	23.8	24	1000	500	2000	1000	0.1	68(61-75)	135	2900
Part No.	Maximum Allowable Voltage		Energy 10/1000 μ S		Withstanding Surge Current 8/20 μ S				Rated POWER (W)	Varistor Voltage	Max Clamping Voltage	Capacitance
	ACrms	DC	Standard	High Surge	Standard (A)		High Surge(A)					
	(V)	(V)	(J)	(J)	1 TIME	2 TIME	1 TIME	2 TIME				
14D820K	50	65	29.4	30.0	4500	2500	6000	5000	0.6	82(74-90)	135	2400
14D101K	60	85	33.6	35.0	4500	2500	6000	5000	0.6	100(90-110)	165	2000
14D121K	75	100	40.6	42.0	4500	2500	6000	5000	0.6	120(108-132)	200	1700
14D151K	95	125	51.8	53.0	4500	2500	6000	5000	0.6	150(135-165)	250	1300
14D181K	115	150	58.8	74.0	4500	2500	6000	5000	0.6	180(162-198)	300	1100
14D201K	130	170	75.2	78.6	4500	2500	6000	5000	0.6	200(185-225)	330	1000
14D221K	140	180	79.8	80.5	4500	2500	6000	5000	0.6	220(198-242)	360	900
14D241K	150	200	82.6	86.0	4500	2500	6000	5000	0.6	240(216-264)	395	830
14D271K	175	225	84.0	94.0	4500	2500	6000	5000	0.6	270(243-297)	455	740
14D301K	190	250	103	105	4500	2500	6000	5000	0.6	300(270-330)	505	670
14D331K	210	275	112	115	4500	2500	6000	5000	0.6	330(297-363)	550	610
14D361K	230	300	123	130	4500	2500	6000	5000	0.6	360(324-396)	595	560
14D391K	250	320	135	140	4500	2500	6000	5000	0.6	390(351-429)	650	510
14D431K	275	350	145	155	4500	2500	6000	5000	0.6	430(387-473)	710	460
14D471K	300	385	147	175	4500	2500	6000	5000	0.6	470(423-517)	775	430
14D511K	320	415	148	180	4500	2500	6000	5000	0.6	510(459-561)	845	390
14D561K	350	460	150	186	4500	2500	6000	5000	0.6	560(504-616)	920	360
14D621K	385	505	155	188	4500	2500	6000	5000	0.6	620(558-682)	1025	320
14D681K	420	560	160	190	4500	2500	6000	5000	0.6	680(612-748)	1120	290
14D751K	460	615	180	210	4500	2500	6000	5000	0.6	750(675-825)	1240	270
14D781K	485	640	190	211	4500	2500	6000	5000	0.6	780(702-858)	1290	260
14D821K	510	670	203	235	4500	2500	6000	5000	0.6	820(738-902)	1355	230
14D911K	550	745	208	255	4500	2500	6000	5000	0.6	910(819-1001)	1500	220
14D102K	625	825	212	280	4500	2500	6000	5000	0.6	1000(900-1100)	1650	200
14D112K	680	895	217	310	4500	2500	6000	5000	0.6	1100(990-1210)	1815	180
14D152K	900	1200	266	420	4500	2500	6000	5000	0.6	1500(1350-1650)	2475	130
14D182K	1000	1465	336	510	4500	2500	6000	5000	0.6	1800(1620-1980)	2970	110

Approval Standard And File Number

Certified Model No.	 E317616		 40028836		 12001078540		CSA & cUL E317616
14D180L	YES				YES		YES
14D220K	YES				YES		YES
14D270K	YES				YES		YES
14D330K	YES		YES		YES		YES
14D390K	YES		YES		YES		YES
14D470K	YES		YES		YES		YES
14D560K	YES		YES		YES		YES
14D680K	YES		YES		YES		YES
14D820K	YES	3ka/6kv	YES		YES		YES
14D101K	YES	3ka/6kv	YES		YES		YES
14D121K	YES	3ka/6kv	YES		YES		YES
14D151K	YES	3ka/6kv	YES		YES		YES
14D181K	YES	3ka/6kv	YES	3ka/6kv	YES		YES
14D201K	YES	3ka/6kv	YES	3ka/6kv	YES		YES
14D221K	YES	3ka/6kv	YES	3ka/6kv	YES		YES
14D241K	YES	3ka/6kv	YES	3ka/6kv	YES		YES
14D271K	YES	3ka/6kv	YES	3ka/6kv	YES		YES
14D301K	YES	3ka/6kv	YES	3ka/6kv	YES		YES
14D331K	YES	3ka/6kv	YES	3ka/6kv	YES		YES
14D361K	YES	3ka/6kv	YES	3ka/6kv	YES		YES
14D391K	YES	3ka/6kv	YES	3ka/6kv	YES		YES
14D431K	YES	3ka/6kv	YES	3ka/6kv	YES	3ka/6kv	YES
14D471K	YES	3ka/6kv	YES	3ka/6kv	YES	3ka/6kv	YES
14D511K	YES	3ka/6kv	YES	3ka/6kv	YES	3ka/6kv	YES
14D561K	YES	3ka/6kv	YES	3ka/6kv	YES	3ka/6kv	YES
14D621K	YES	3ka/6kv	YES	3ka/6kv	YES	3ka/6kv	YES
14D681K	YES	3ka/6kv	YES	3ka/6kv	YES	3ka/6kv	YES
14D751K	YES	3ka/6kv	YES	3ka/6kv	YES	3ka/6kv	YES
14D821K	YES	3ka/6kv			YES	3ka/6kv	YES
14D911K	YES	3ka/6kv			YES	3ka/6kv	YES
14D102K	YES	3ka/6kv			YES	3ka/6kv	YES
14D112K	YES	3ka/6kv			YES	3ka/6kv	YES
14D152K	YES	3ka/6kv			YES	3ka/6kv	YES
14D182K	YES	3ka/6kv			YES	3ka/6kv	YES

Power Derating Curve

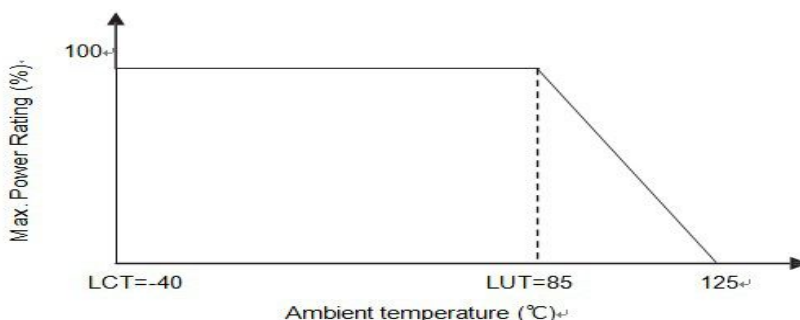

VARISTOR V - I CHARACTERISTICS

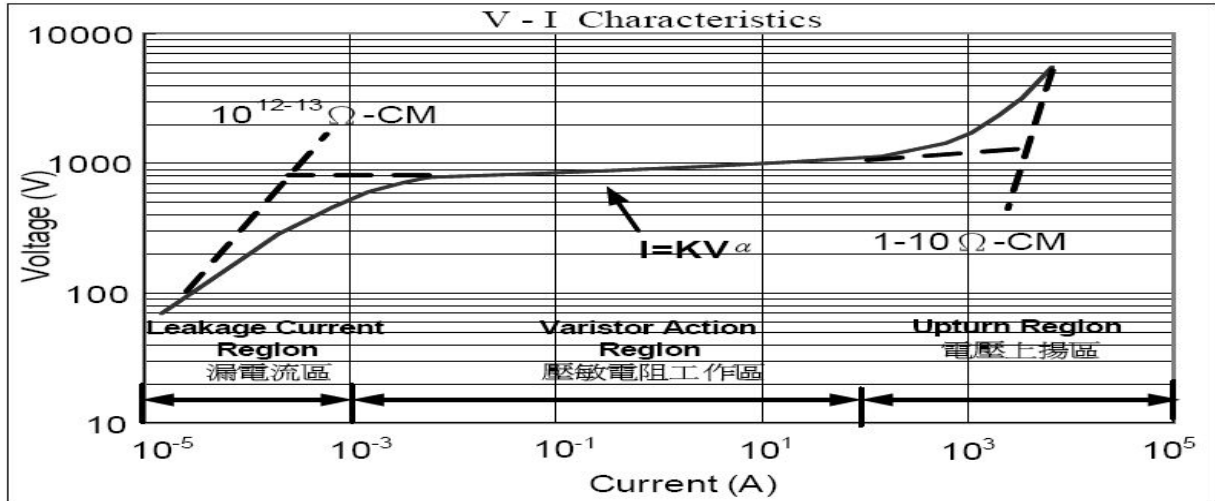

Surge Life Time Ratings N (Standard) / K (Low Capacitance) Series

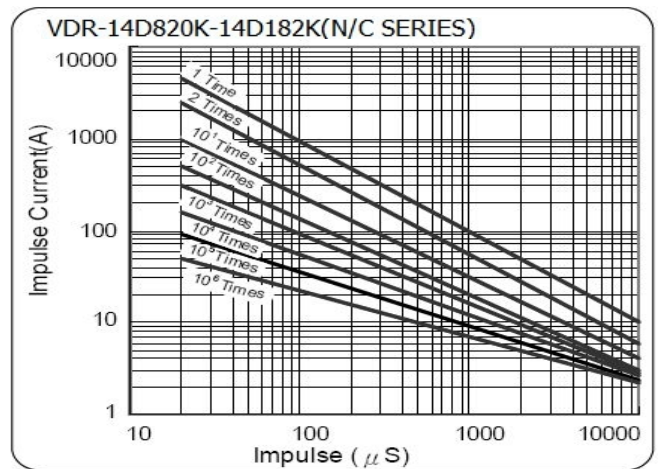
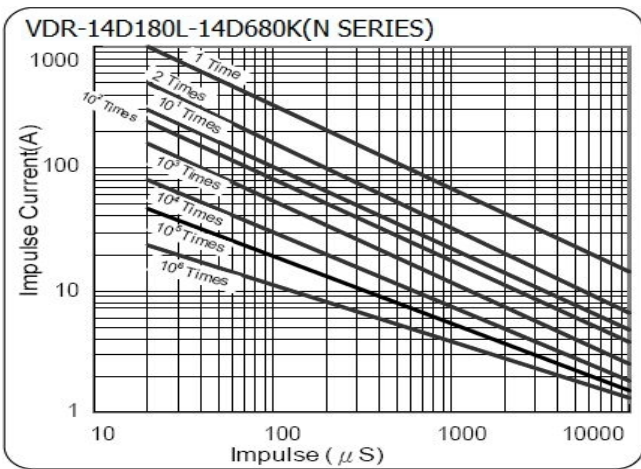

Soldering Recommendation
Wave Soldering Profile

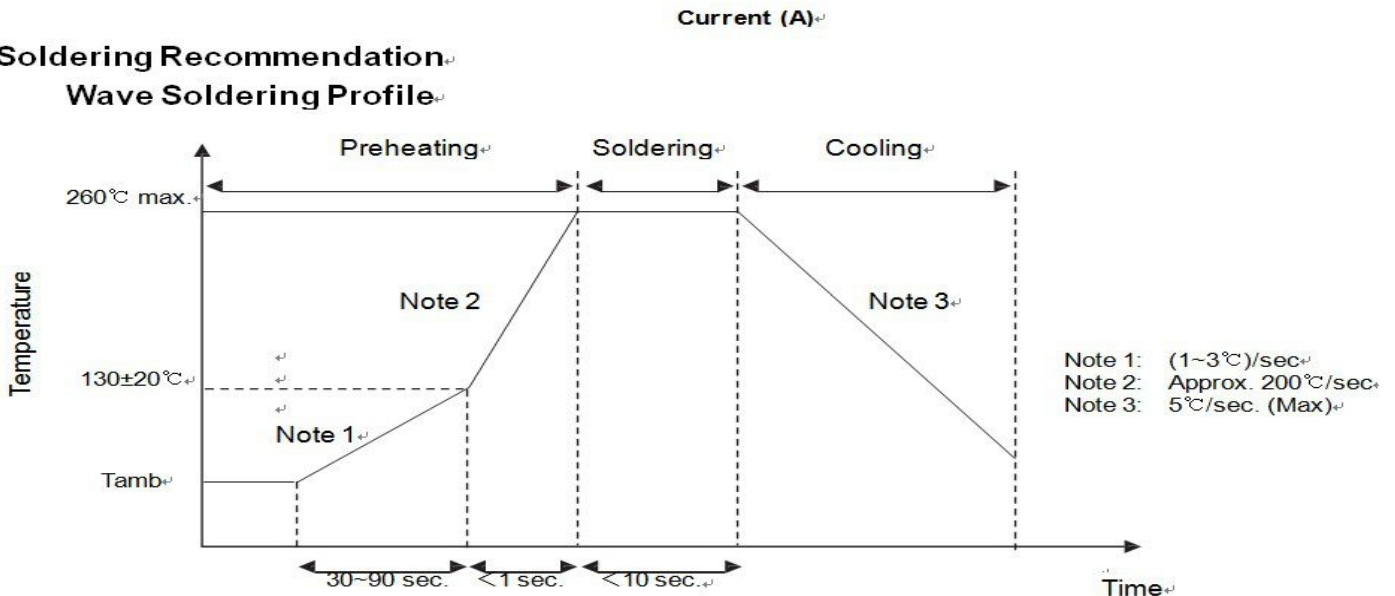

V-I CURVE

VDR-14D180L-14D680K(N/J/S SERIES)

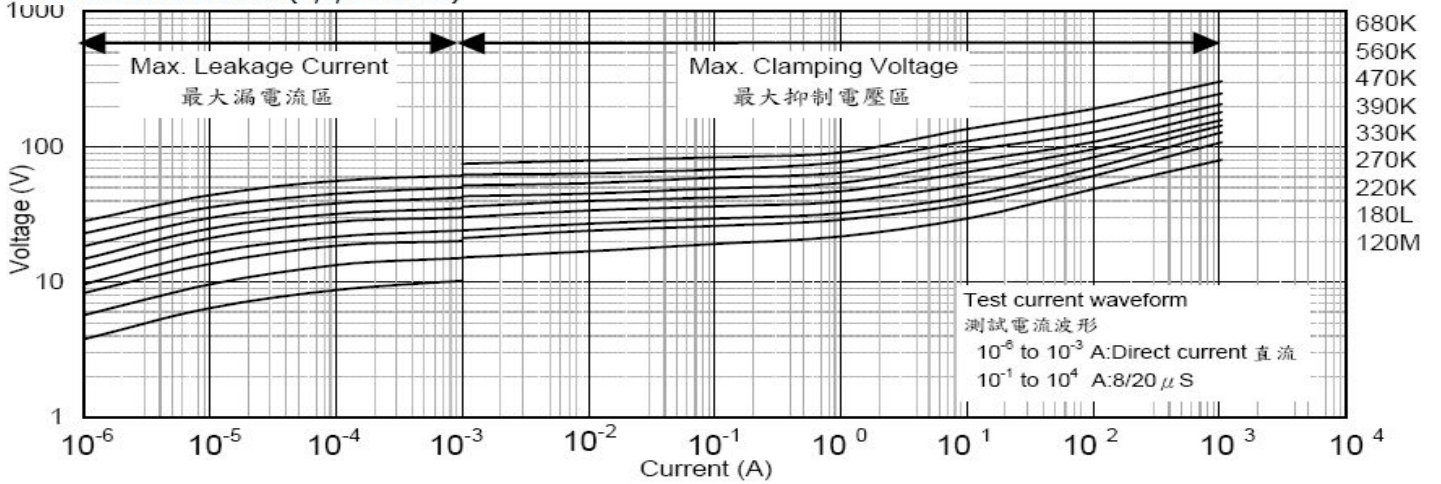

VDR-14D820K-14D431K(N/J/S SERIES)

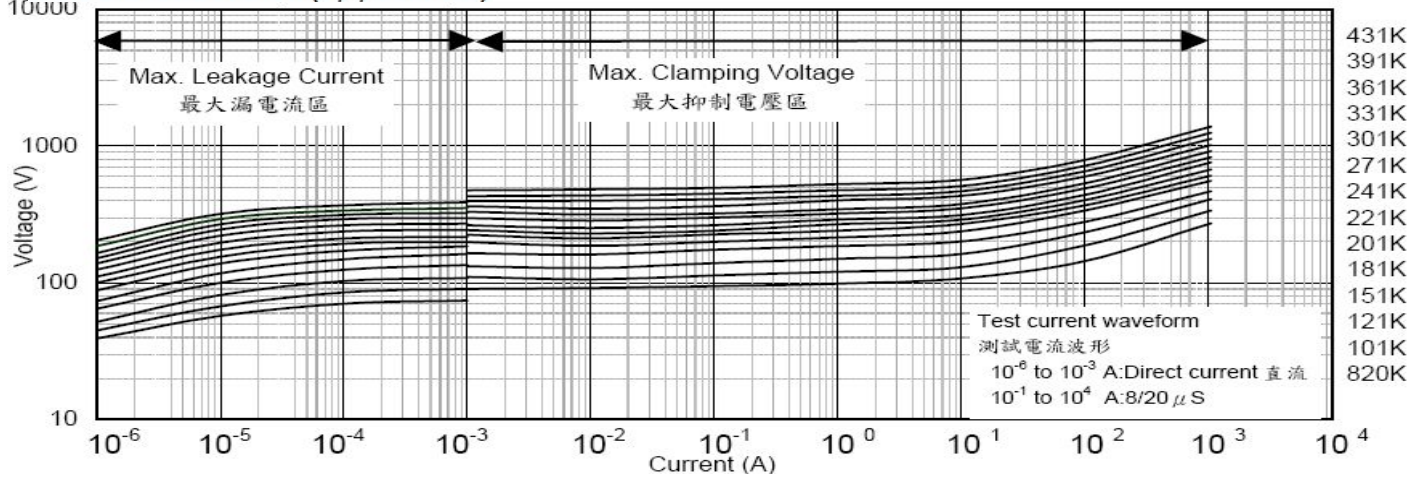

VDR-14D471K-14D182K(N/J/S SERIES)

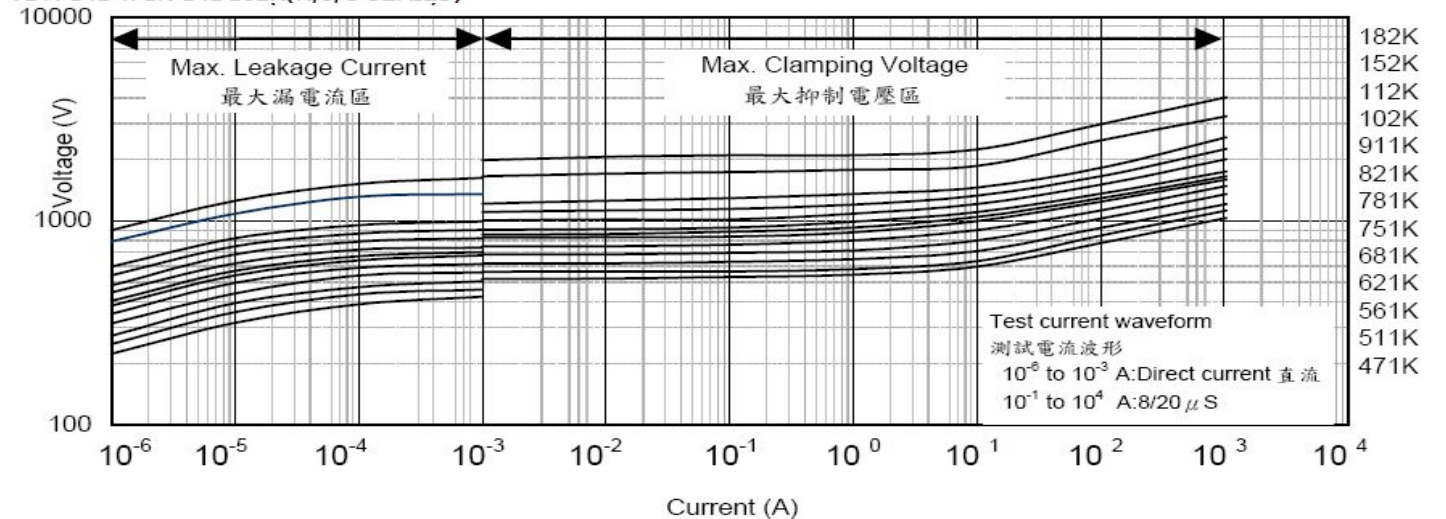

Dimension - TA / TR / CA / CR Ammo & Reel Series

Straight Leads (5D,7D,10D)

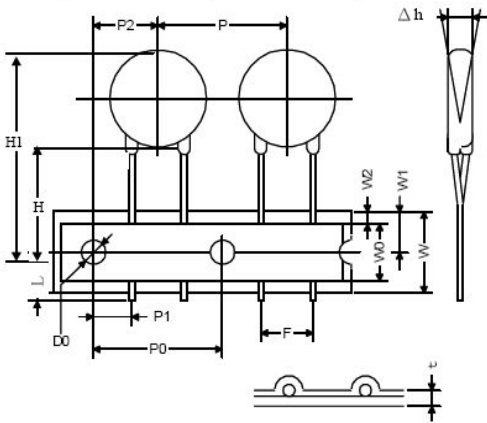

Crimped Leads (5D,7D,10D)

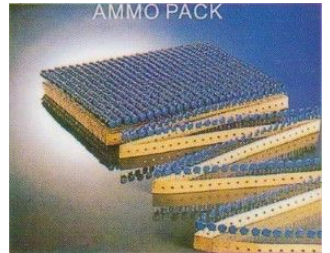
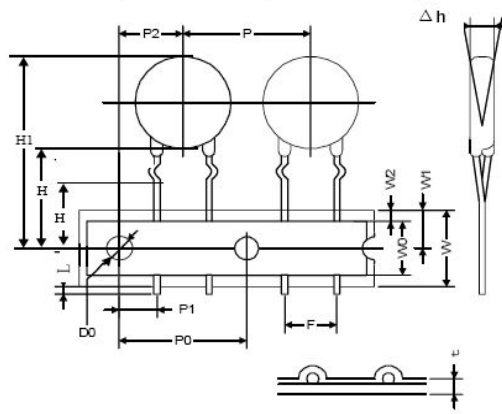

Straight Leads (10D,14D,20D)

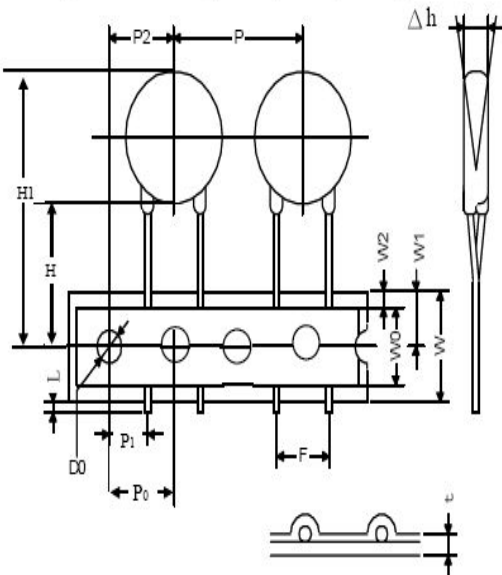

Crimped Leads (10D,14D,20D)

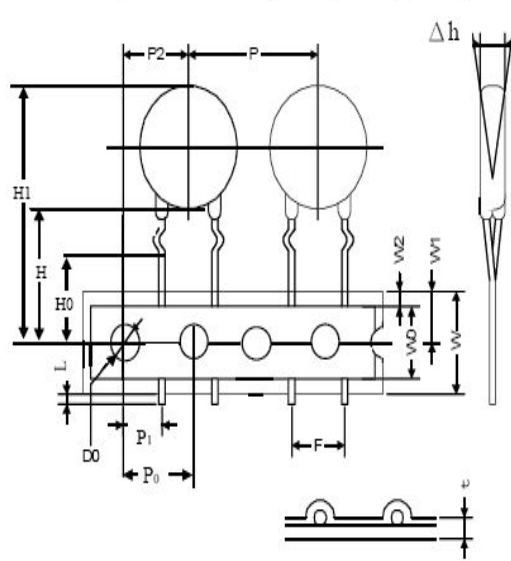

Packing	Dimensions	Symbol	Dimensions (mm)				
			5D	7D	9/10D	14D	18/20D
AMMO		LP	330mm	335mm	345mm		
		WP	310mm	243mm	345mm		
		HP	50mm	50mm	65mm		
		Carton	350x270x330	355x260x537	360x360x480		
REEL		RD	360mm	340mm			
		RD1	30 ± 0.5mm	30 ± 0.5mm			
		RW	45mm	51mm	53mm		
		RW1	50mm	56mm	58mm		
		LP	365mm	345mm			
		WP	365mm	345mm			
		HP	57mm	65mm			
		Carton	380x380x480	360x360x480			

Unit: pcs

Reel		Ammo	
Box	Carton	Box	Carton
2000	16000	2000	10000
		1500	7500
2000	16000	2000	10000
		1500	7500
500	3500	500	5000
500	3500	500	5000
400	2800	500	5000
400	2800	400	2800
300	2100	300	2100

Quality Per Packing Method

Dimension	Part No.	Ammo		Reel	
		Box	Carton	Box	Carton
14D	180L to 471K	1,000	10,000	500	2,000
14D	511k to 821K	800	8,000	300	1,200

Packing Specifications /Bulk Packing Dimension /Quantity per Packing Method

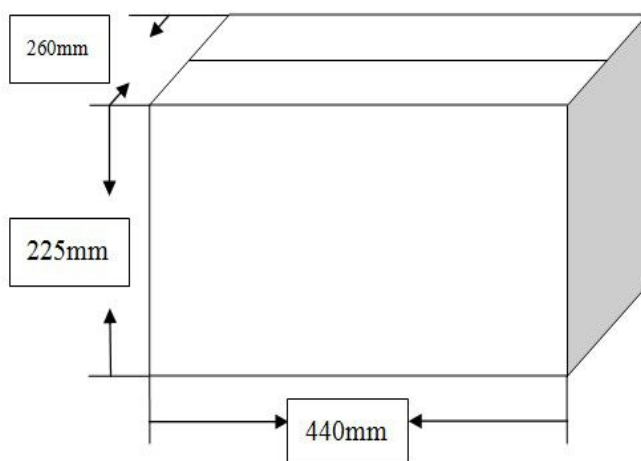

Unit:Pcs

Dimension	Part No.	Bag	Small Carton	Carton
14D	180L to 681K	500	3,000	6,000
14D (Short leg)	180L to 681K	500	4,000	8,000
14D	751K to 182K	500	2,500	5,000
14D (Short leg)	751K to 182K	500	3,000	6,000

Marking

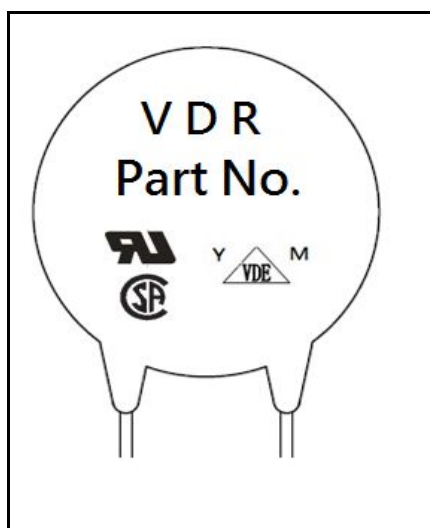

Marking	
Trademark	VDR
Part No.	14D180L-182K
Standard for Safety	UL / VDE / CQC
Date Code:	Y : Year M : Month
J	High Surge
E* / S* / Y*	4KV/2KA /6KV/3KA /10KV/5KA

Reliability Test

Mechanical Ratings

Test Parameter	Test Condition / Description			Performance Requirements
Terminal Pull Strength	After gradually applying the load specified below and keeping the unit fixed for ten seconds, the terminal shall be visually examined for any damage.	Diameter	Loading	No visible damage
		0.6mm	1.0 Kg	
		0.8mm	1.0 Kg	
		1.0mm	2.0 Kg	
Terminal Bending Strength	The unit shall be secured with its terminal kept vertical and the weight specified below be applied in the axial direction. The terminal shall gradually be bent by 90° in one direction, then 90° in the opposite direction, and again back to the original position. The damage of the terminal shall be visually examined.	Diameter	Loading	No visible damage
		0.6mm	0.5 Kg	
		0.8mm	0.5 Kg	
		1.0mm	1.0 Kg	
Vibration	The Specimen shall be vibrated by its lead wires with a total amplitude of 1.5mm and a varying frequency of 10~55~10HZ(each minutes) for a period of 2 hours respectively in each X,Y and Z directions.			No visible damage VB/VB% ≤ ±5% △
Soldering-solderability	After dipping the terminal to depth of approximately 3mm from the specimen in a soldering bath of 260°C for 10±1(D5: 5±1) seconds. Thereafter the terminal shall be visually examined.			Terminations shall be uniformly tinned
Soldering- Resistance to Solder Heat	After preheating the specimen, the specimen shall be completely immersed into a soldering bath having a temperature of 260±5°C for 10±1 (D5: 5±1) seconds or iron of 400±5°C for 3±0.5 seconds. There after the change of Vb and mechanical damage shall be examined.			No visible damage VB/VB% ≤ ±5% △

ENVIRONMENTAL RATINGS

Dry Heat Loading	The specimen shall be applied continuously the maximum allowable voltage at the specified conditions for specified period and then stored at room temperature and normal humidity over 2 hours. Thereafter, the change of Vb and mechanical damage shall be examined. Ambient temp : 125±2°C ; Period : 1000±24hours.			△VB/VB% ≤ ±10%	
High Temperature Storage	In a drying oven without load. Ambient temp : 125±2°C ; period : 1000±24hours			△VB/VB% ≤ ±5%	
Damp Heat Loading	The specimen shall be applied continuously the maximum allowable voltage at the specified conditions for specified period and then stored at room temperature and normal humidity over 2 hours. Thereafter, the change of Vb and mechanical damage shall be examined. Ambient condition : 40±2°C , 90 to 95%R.H. ; period : 1000±24 hours			△VB/VB% ≤ ±10%	
Temperature Cycle	Condition the specimen to each temperature form step 1 to step 4 in this order for the period shown in the table of specifications. The change of Vb and mechanical damage shall be examined after 2 hours.	Step	Temp°C	Period	No visible damage △VB/VB% ≤ ±10%
		1	-40±3°C	30 min.	
		2	Room Temp	15 min.	
		3	85±2°C	30 min.	
		4	Room Temp	15 min.	
Surge Lifetime Rating	The change of Vb shall be measured after the impulse listed below is applied 10,000 times continuously with the interval of ten seconds at room temperature.			No visible damage △VB/VB% ≤ ±10%	
Voltage Proof	Voltage : 2500VAC Leakage Current ≤ 0.5mA Time : 60 Seconds			No Breakdown	