



**DONGGUAN NANJING ELECTRONICS LTD.,**  
**SOT-23 Plastic-Encapsulate Transistors**

**MMBT4403** TRANSISTOR (PNP)

**FEATURES**

Switching transistor

**MARKING : 2T**

**MAXIMUM RATINGS (T<sub>a</sub>=25°C unless otherwise noted)**

Symbol	Parameter	Value	Unit
V <sub>CBO</sub>	Collector-Base Voltage	-40	V
V <sub>CEO</sub>	Collector-Emitter Voltage	-40	V
V <sub>EBO</sub>	Emitter-Base Voltage	-5	V
I <sub>C</sub>	Collector Current -Continuous	-0.6	A
P <sub>C</sub>	Collector Power Dissipation	0.3	W
T <sub>j</sub>	Junction Temperature	150	°C
T <sub>stg</sub>	Storage Temperature	-55-150	°C

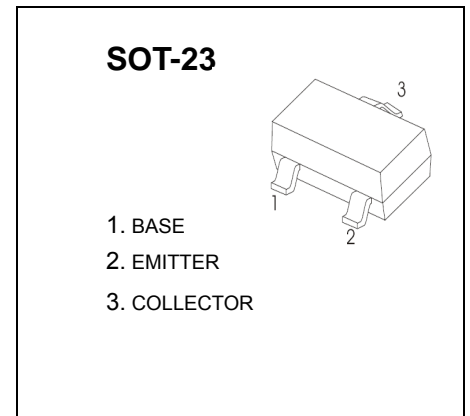

**ELECTRICAL CHARACTERISTICS (T<sub>a</sub>=25°C unless otherwise specified)**

Parameter	Symbol	Test conditions	Min	Max	Unit
Collector-base breakdown voltage	V <sub>(BR)CBO</sub>	I <sub>C</sub> =-100μA, I <sub>E</sub> =0	-40		V
Collector-emitter breakdown voltage	V <sub>(BR)CEO</sub>	I <sub>C</sub> = -1mA, I <sub>B</sub> =0	-40		V
Emitter-base breakdown voltage	V <sub>(BR)EBO</sub>	I <sub>E</sub> =-100μA, I <sub>C</sub> =0	-5		V
Collector cut-off current	I <sub>CBO</sub>	V <sub>CB</sub> =-35V, I <sub>E</sub> =0		-0.1	μA
Collector cut-off current	I <sub>CEO</sub>	V <sub>CE</sub> =-35 V, I <sub>B</sub> =0		-0.1	μA
Emitter cut-off current	I <sub>EBO</sub>	V <sub>EB</sub> =-4V, I <sub>C</sub> =0		-0.1	μA
DC current gain	h <sub>FE</sub>	V <sub>CE</sub> =-2V, I <sub>C</sub> = -150mA	100	300	
Collector-emitter saturation voltage	V <sub>CE(sat)</sub>	I <sub>C</sub> =-150mA, I <sub>B</sub> =-15mA		-0.4	V
Base-emitter saturation voltage	V <sub>BE(sat)</sub>	I <sub>C</sub> =- 150mA, I <sub>B</sub> =-15mA		-0.95	V
Transition frequency	f <sub>T</sub>	V <sub>CE</sub> = -10V, I <sub>C</sub> = -20mA f = 100MHz	200		MHz
Delay time	t <sub>d</sub>	V <sub>CC</sub> =-30V, V <sub>EB</sub> =-2V, I <sub>C</sub> =-150mA, I <sub>B1</sub> =-15mA		15	ns
Rise time	t <sub>r</sub>			20	ns
Storage time	t <sub>s</sub>	V <sub>CC</sub> =-30V, I <sub>C</sub> =-150mA.		225	ns
Fall time	t <sub>f</sub>	I <sub>B1</sub> = I <sub>B2</sub> =-15mA		30	ns

# Typical Characteristics

# MMBT4403

