



DONGGUAN NANJING ELECTRONICS LTD.,

NPN Silicon Epitaxial Planar Transistor

2SD1766

FEATURES

- Low saturation voltage: $V_{CE(sat)}=0.5V(\text{Typ.})$
- $P_C=0.5W$ (Mounted on ceramic substrate)
- Small flat package.
- Complementary pair with 2SB1188.

APPLICATIONS

- Power amplifier application.

ORDERING INFORMATION

Type No.	Marking	Package Code
2SD1766	DBP/DBQ/DBR	SOT-89

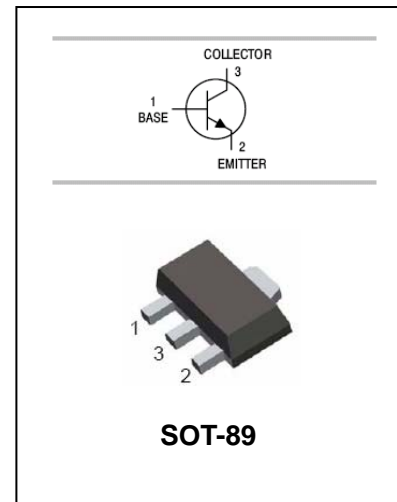

MAXIMUM RATING @ $T_a=25^{\circ}\text{C}$ unless otherwise specified

Symbol	Parameter	Value	Units
V_{CBO}	Collector-Base Voltage	40	V
V_{CEO}	Collector-Emitter Voltage	32	V
V_{EBO}	Emitter-Base Voltage	5	V
I_C	Collector Current -Continuous	2	A
P_C	Collector Dissipation	500	mW
T_j, T_{stg}	Junction and Storage Temperature	-55 to +150	$^{\circ}\text{C}$

NPN Silicon Epitaxial Planar Transistor

2SD1766

ELECTRICAL CHARACTERISTICS @ Ta=25°C unless otherwise specified

Parameter	Symbol	Test conditions	MIN	TYP	MAX	UNIT
Collector-base breakdown voltage	$V_{(BR)CBO}$	$I_C=50\mu A, I_E=0$	40			V
Collector-emitter breakdown voltage	$V_{(BR)CEO}$	$I_C=1mA, I_B=0$	32			V
Emitter-base breakdown voltage	$V_{(BR)EBO}$	$I_E=50\mu A, I_C=0$	5			V
Collector cut-off current	I_{CBO}	$V_{CB}=20V, I_E=0$			1	μA
Emitter cut-off current	I_{EBO}	$V_{EB}=4V, I_C=0$			1	μA
DC current gain	h_{FE}	$V_{CE}=3V, I_C=500mA$	82		390	
Collector-emitter saturation voltage	$V_{CE(sat)}$	$I_C=2A, I_B=200mA$		0.5	0.8	V
Transition frequency	f_T	$V_{CE}=5V, I_E=50mA,$ $f=100MHz$		100		MHz
Collector output capacitance	C_{ob}	$V_{CB}=10V, I_E=0, f=1MHz$		30		pF

CLASSIFICATION OF h_{FE}

Rank	P	Q	R
Range	82-180	120-270	180-390
MARKING	DBP	DBQ	DBR

NPN Silicon Epitaxial Planar Transistor

2SD1766

TYPICAL CHARACTERISTICS @ $T_a=25^\circ\text{C}$ unless otherwise specified

Fig. 1 $P_C - T_a$

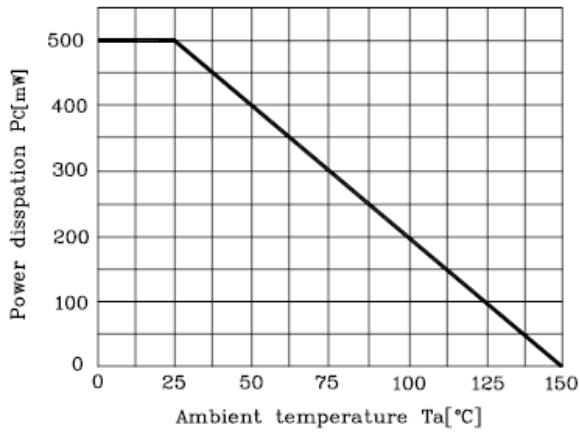

Fig. 2 $I_C - V_{BE}$

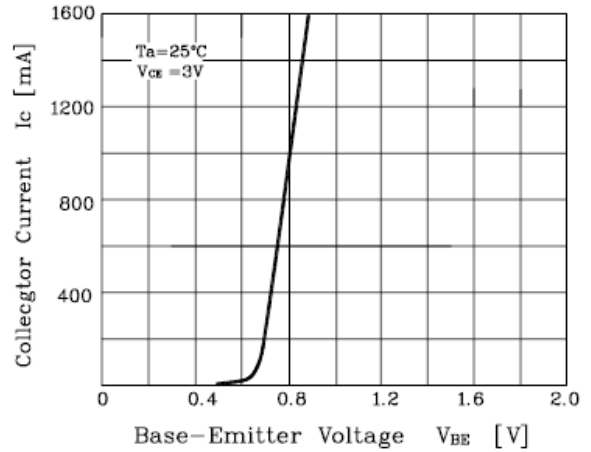

Fig. 3 $I_C - V_{CE}$

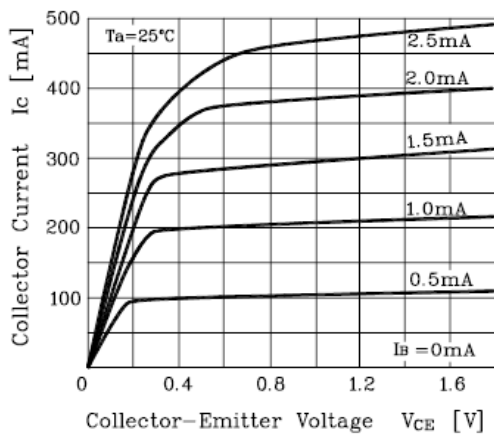
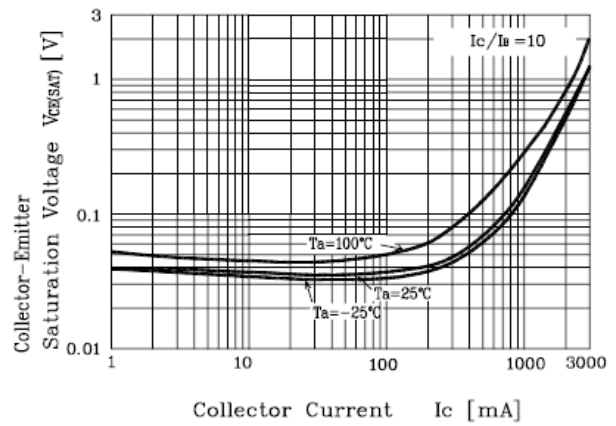

Fig. 4 $V_{CE(sat)} - I_C$



NPN Silicon Epitaxial Planar Transistor

2SD1766

PACKAGE OUTLINE

Plastic surface mounted package

SOT-89

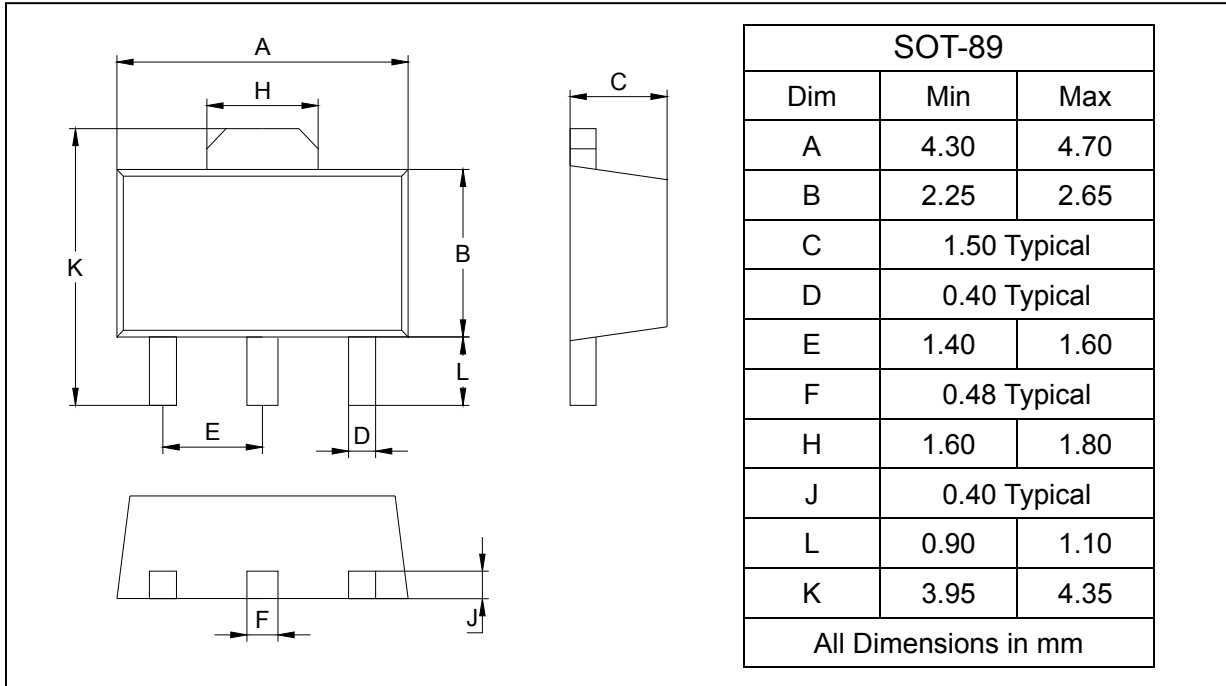

SOLDERING FOOTPRINT

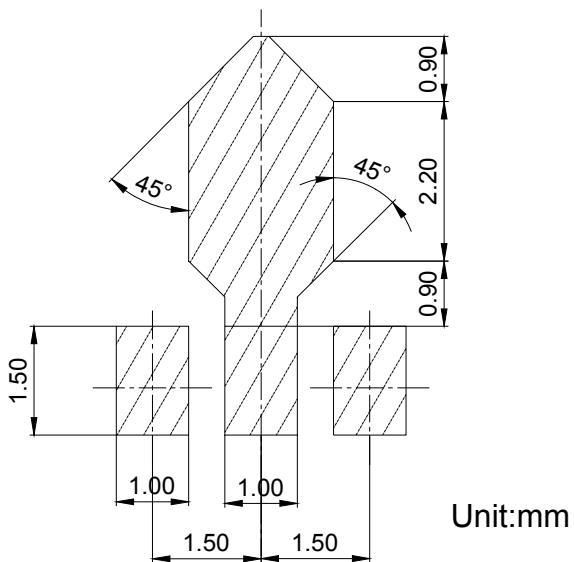

PACKAGE INFORMATION

Device	Package	Shipping
2SD1766	SOT-89	1000/Tape&Reel