



# DONGGUAN NANJING ELECTRONICS LTD.,

## TO-92 Plastic-Encapsulate Transistors

### 2SC2120 TRANSISTOR (NPN)

#### FEATURES

- High DC Current Gain
- Complementary to 2SA950

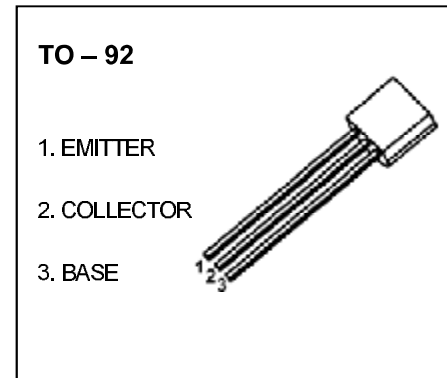

#### MARKING

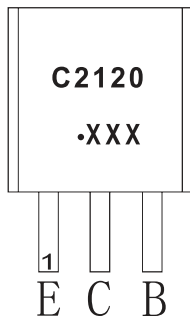

C2120=Device code  
 Solid dot=Green molding compound device,  
 if none,the normal device  
 XXX=Code

#### Equivalent Circuit

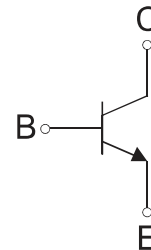

#### ORDERING INFORMATION

| Part Number | Package | Packing Method | Pack Quantity |
|-------------|---------|----------------|---------------|
| 2SC2120     | TO-92   | Bulk           | 1000pcs/Bag   |
| 2SC2120-TA  | TO-92   | Tape           | 2000pcs/Box   |

#### MAXIMUM RATINGS (T<sub>a</sub>=25°C unless otherwise noted)

| Symbol           | Parameter                                   | Value    | Unit  |
|------------------|---|----------|-------|
| V <sub>CBO</sub> | Collector-Base Voltage                      | 35       | V     |
| V <sub>CEO</sub> | Collector-Emitter Voltage                   | 30       | V     |
| V <sub>EBO</sub> | Emitter-Base Voltage                        | 5        | V     |
| I <sub>C</sub>   | Collector Current                           | 0.8      | A     |
| P <sub>C</sub>   | Collector Power Dissipation                 | 600      | mW    |
| R <sub>θJA</sub> | Thermal Resistance From Junction To Ambient | 208      | °C /W |
| T <sub>J</sub>   | Junction Temperature                        | 150      | °C    |
| T <sub>stg</sub> | Storage Temperature                         | -55~+150 | °C    |

---

## ELECTRICAL CHARACTERISTICS

---

$T_a=25\text{ }^\circ\text{C}$  unless otherwise specified

| Parameter                            | Symbol        | Test conditions                           | Min | Typ | Max | Unit          |
|--------------------------------------|---------------|---|-----|-----|-----|---------------|
| Collector-base breakdown voltage     | $V_{(BR)CBO}$ | $I_C=0.1\text{mA}, I_E=0$                 | 35  |     |     | V             |
| Collector-emitter breakdown voltage  | $V_{(BR)CEO}$ | $I_C=10\text{mA}, I_B=0$                  | 30  |     |     | V             |
| Emitter-base breakdown voltage       | $V_{(BR)EBO}$ | $I_E=0.1\text{mA}, I_C=0$                 | 5   |     |     | V             |
| Collector cut-off current            | $I_{CBO}$     | $V_{CB}=35\text{V}, I_E=0$                |     |     | 0.1 | $\mu\text{A}$ |
| Collector cut-off current            | $I_{CEO}$     | $V_{CE}=25\text{V}, I_B=0$                |     |     | 0.1 | $\mu\text{A}$ |
| Emitter cut-off current              | $I_{EBO}$     | $V_{EB}=5\text{V}, I_C=0$                 |     |     | 0.1 | $\mu\text{A}$ |
| DC current gain                      | $h_{FE}$      | $V_{CE}=1\text{V}, I_C=100\text{mA}$      | 100 |     | 320 |               |
| Collector-emitter saturation voltage | $V_{CE(sat)}$ | $I_C=500\text{mA}, I_B=20\text{mA}$       |     |     | 0.5 | V             |
| Base-emitter voltage                 | $V_{BE}$      | $V_{CE}=1\text{V}, I_C=10\text{mA}$       |     |     | 0.8 | V             |
| Collector output capacitance         | $C_{cb}$      | $V_{CB}=10\text{V}, I_E=0, f=1\text{MHz}$ |     |     | 13  | pF            |
| Transition frequency                 | $f_T$         | $V_{CE}=5\text{V}, I_C=10\text{mA}$       | 100 |     |     | MHz           |

### CLASSIFICATION OF $h_{FE}$

| RANK  | O       | Y       |
|-------|---------|---------|
| RANGE | 100-200 | 160-320 |

# Typical Characteristics

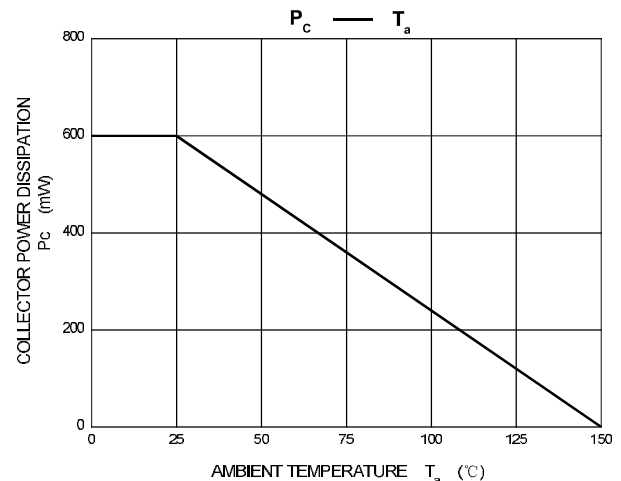
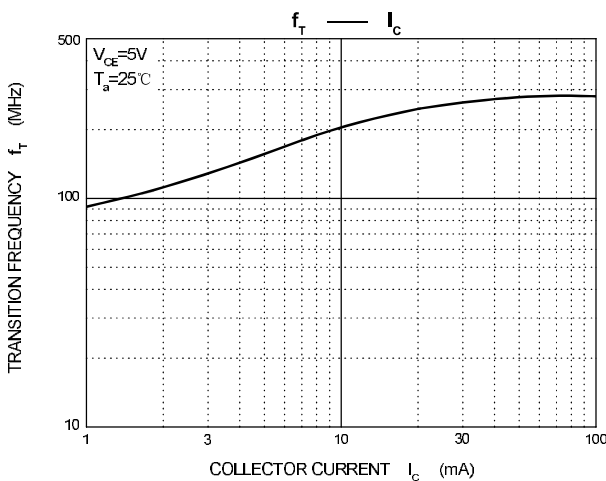
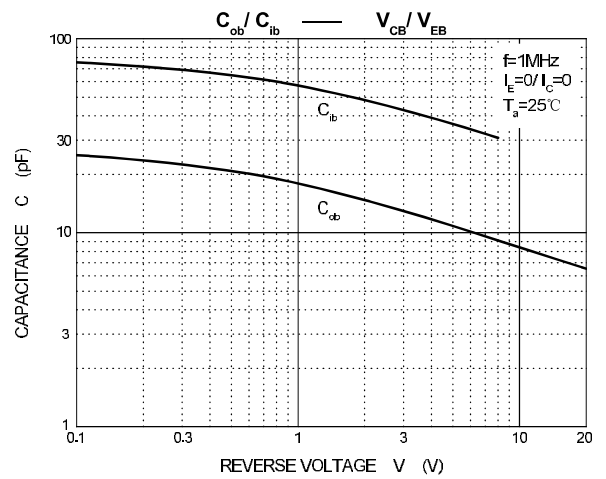
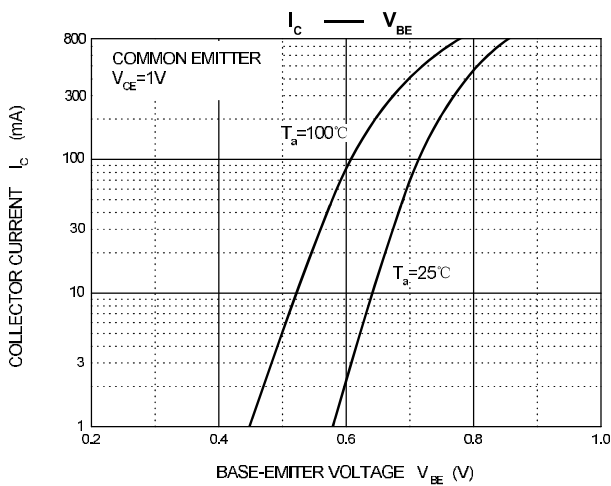
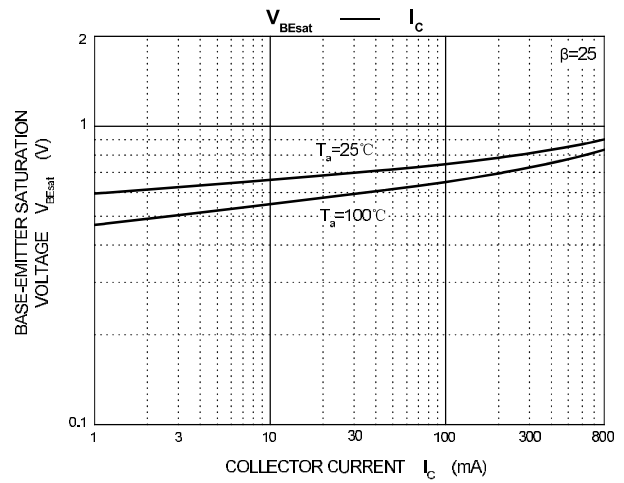
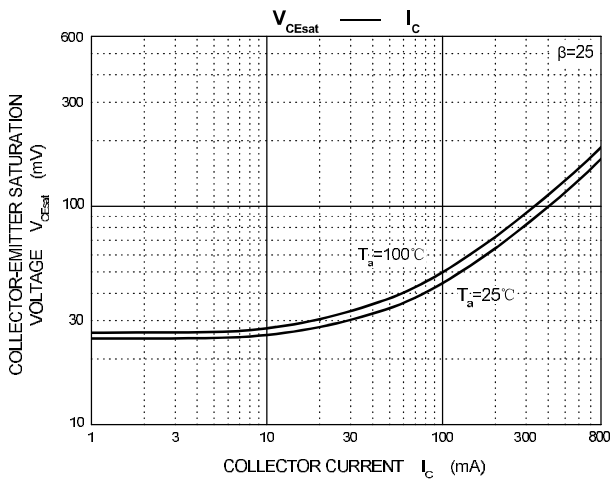
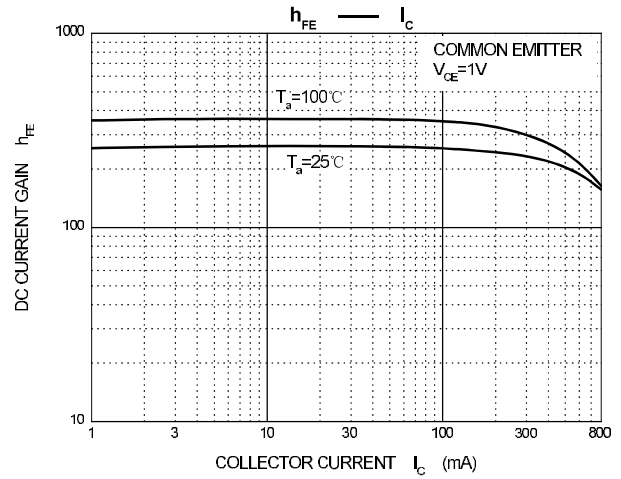
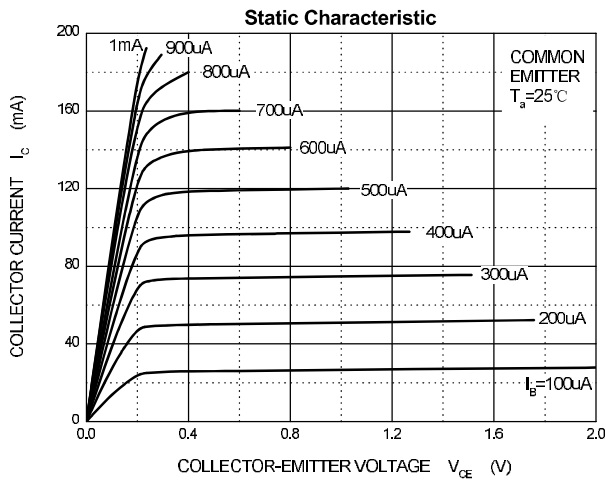

## TO-92 Package Outline Dimensions

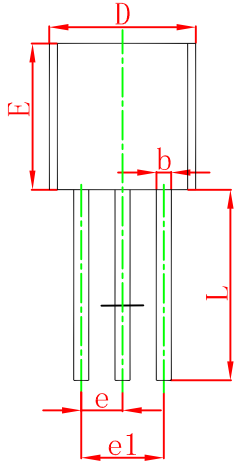
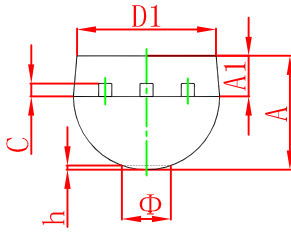

| Symbol | Dimensions In Millimeters |        | Dimensions In Inches |       |
|--------|---------------------------|--------|----------------------|-------|
|        | Min                       | Max    | Min                  | Max   |
| A      | 3.300                     | 3.700  | 0.130                | 0.146 |
| A1     | 1.100                     | 1.400  | 0.043                | 0.055 |
| b      | 0.380                     | 0.550  | 0.015                | 0.022 |
| c      | 0.360                     | 0.510  | 0.014                | 0.020 |
| D      | 4.300                     | 4.700  | 0.169                | 0.185 |
| D1     | 3.430                     |        | 0.135                |       |
| E      | 4.300                     | 4.700  | 0.169                | 0.185 |
| e      | 1.270 TYP                 |        | 0.050 TYP            |       |
| e1     | 2.440                     | 2.640  | 0.096                | 0.104 |
| L      | 14.100                    | 14.500 | 0.555                | 0.571 |
| Φ      |                           | 1.600  |                      | 0.063 |
| h      | 0.000                     | 0.380  | 0.000                | 0.015 |

## TO-92 Suggested Pad Layout

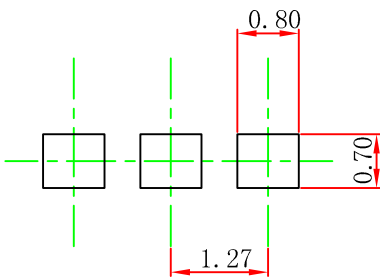

### Note:

1. Controlling dimension: in millimeters.
2. General tolerance:  $\pm 0.05\text{mm}$ .
3. The pad layout is for reference purposes only.

TO-92 PACKAGE TAPEING DIMENSION

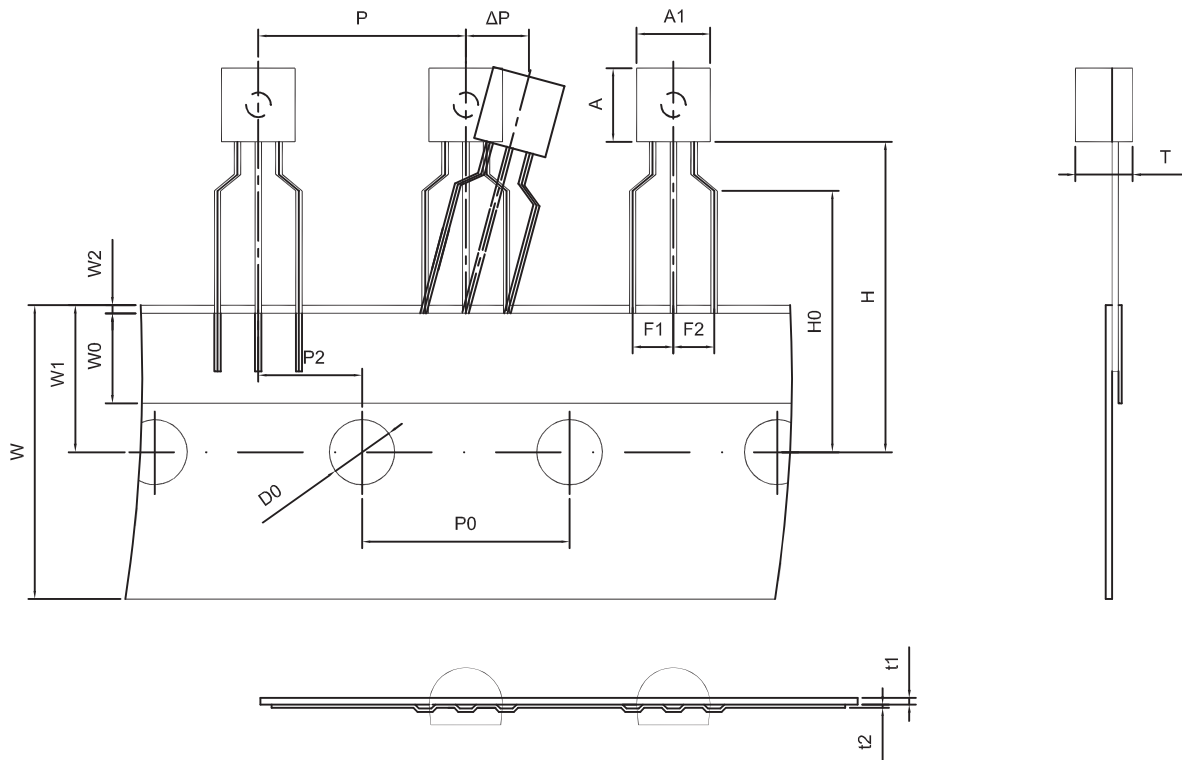

Dimiensions are in millimeter

| A1  | A   | T        | P    | P0   | P2   | F1  | F2  | W    |
|-----|-----|----------|------|------|------|-----|-----|------|
| 4.5 | 4.5 | 3.5      | 12.7 | 12.7 | 6.35 | 2.5 | 2.5 | 18.0 |
| W0  | W1  | W2       | H    | H0   | D0   | t1  | t2  | ΔP   |
| 6.0 | 9.0 | 1.0 MAX. | 19.0 | 16.0 | 4.0  | 0.4 | 0.2 | 0    |

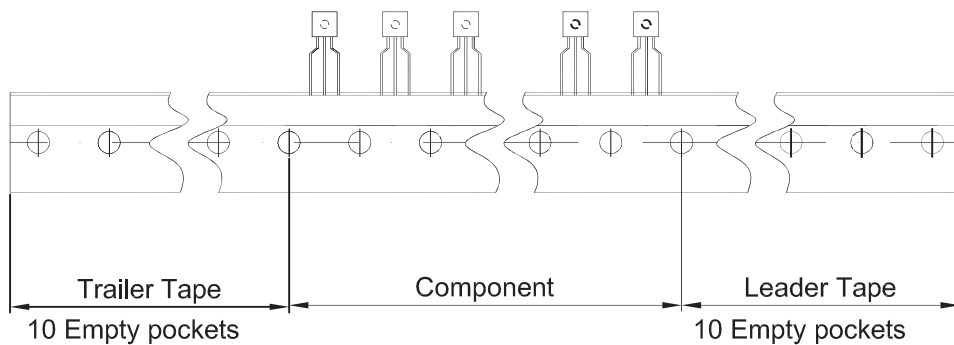

| Package | Box      | Box Size(mm) | Carton     | Carton Size(mm) |
|---------|----------|--------------|------------|-----------------|
| TO-92   | 2000 pcs | 333×162×43   | 20,000 pcs | 350×340×250     |