



DONGGUAN NANJING ELECTRONICS LTD.,
TO-92 Encapsulate Adjustable Reference Source

TL431 Adjustable Accurate Reference Source

FEATURES

- The output voltage can be adjusted to 36V
- Low dynamic output impedance ,its typical value is 0.2Ω
- Trapping current capability is 1 to 100mA
- The typical value of the equivalent temperature factor in the whole temperature scope is 50 ppm/°C
- The effective temperature compensation in the working range of full temperature
- Low output noise voltage
- Fast on -state response

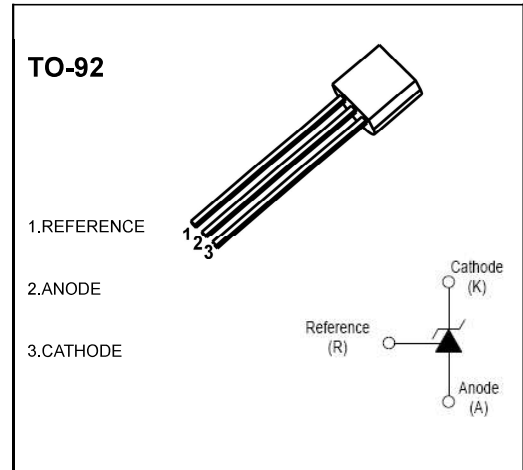

ABSOLUTE MAXIMUM RATINGS (Operating temperature range applies unless otherwise specified)

Parameter	SYMBOL	VALUE	UNITS
Cathode Voltage	V_{KA}	37	V
Cathode Current Range (Continuous)	I_{KA}	-100~+150	mA
Reference Input Current Range	I_{ref}	0.05~+10	mA
Power Dissipation	P_D	770	mW
Thermal Resistance from Junction to Ambient	$R_{\theta JA}$	162	°C/W
Operating Ambient Temperature Range	T_A	0~+70	°C
Storage temperature Range	T_{stg}	-65~+150	°C
Operating Junction Temperature	T_j	150	°C

ELECTRICAL CHARACTERISTICS ($T_a=25^\circ\text{C}$ unless otherwise specified)

Parameter	Symbol	Test conditions	MIN	TYP	MAX	UNIT
Reference Input Voltage (Fig.1)	V_{ref}	$V_{KA}=V_{REF}, I_{KA}=10\text{mA}$	2.450	2.5	2.550	V
Deviation of reference input Voltage Over temperature (note) (Fig.1)	$\Delta V_{ref}/\Delta T$	$V_{KA}=V_{REF}, I_{KA}=10\text{mA}$ $T_{min}\leq T_a\leq T_{max}$		4.5	17	mV
Ratio Of Change in Reference Input Voltage to the change in Cathode Voltage (Fig.2)	$\Delta V_{ref}/\Delta V_{KA}$	$I_{KA}=10\text{mA}$	$\Delta V_{KA}=10\text{V}\sim V_{REF}$	-1.0	-2.7	mV/V
			$\Delta V_{KA}=36\text{V}\sim 10\text{V}$	-0.5	-2.0	mV/V
Reference Input Current (Fig.2)	I_{ref}	$I_{KA}=10\text{mA}, R_1=10\text{K}\Omega$ $R_2=\infty$		1.5	4	μA
Deviation Of Reference Input Current Over Full Temperature Range(Fig.2)	$\Delta I_{ref}/\Delta T$	$I_{KA}=10\text{mA}, R_1=10\text{K}\Omega$ $R_2=\infty$ $T_A=\text{full Temperature}$		0.4	1.2	μA
Minimum cathode current for regulation (Fig.1)	$I_{KA(\text{min})}$	$V_{KA}=V_{REF}$		0.45	1.0	mA
Off-state cathode Current(Fig.3)	$I_{KA(\text{OFF})}$	$V_{KA}=36\text{V}, V_{REF}=0$		0.05	1.0	μA
Dynamic Impedance	Z_{KA}	$V_{KA}=V_{REF}, I_{KA}=1\text{ to }100\text{mA}$ $f\leq 1.0\text{KHz}$		0.15	0.5	Ω

Note: $T_{MIN}=0^\circ\text{C}$, $T_{MAX}=+70^\circ\text{C}$

CLASSIFICATION OF V_{ref}

Rank	0.4%	0.5%	1%	2%
Range	2.49-2.50	2.487-2.513	2.475-2.525	2.450-2.550

Figure 1. Test Circuit for $V_{KA} = V_{ref}$

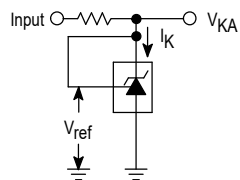

Figure 2. Test Circuit for $V_{KA} > V_{ref}$

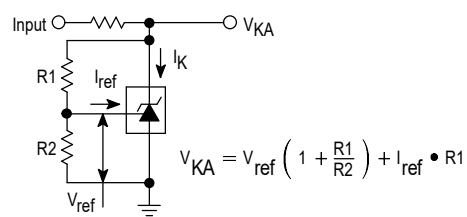
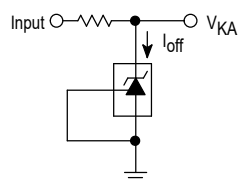

Figure 3. Test Circuit for I_{off}



Typical Characteristics

TL431

Cathode Current versus Cathode Voltage

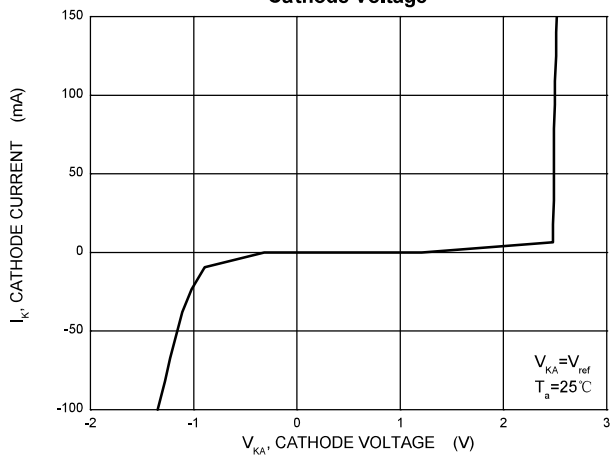

Cathode Current versus Cathode Voltage

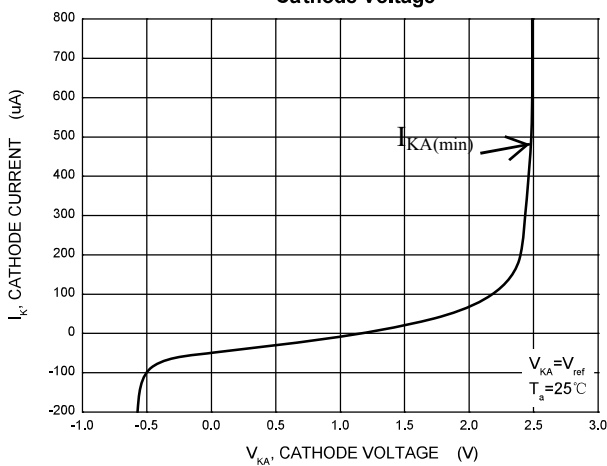

Reference Input Voltage versus Ambient Temperature

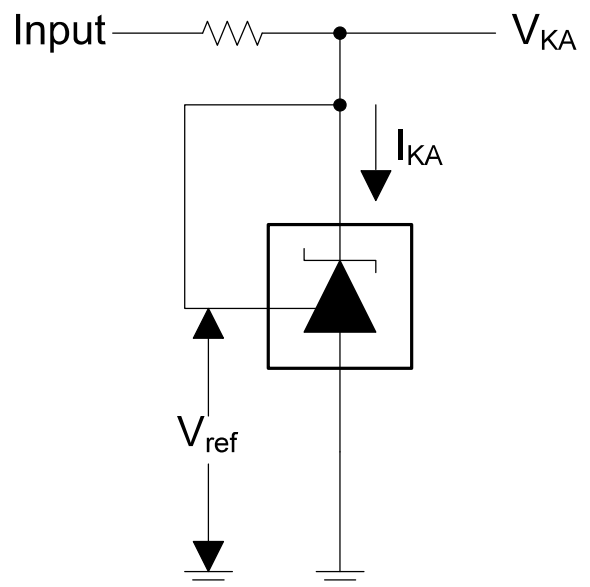
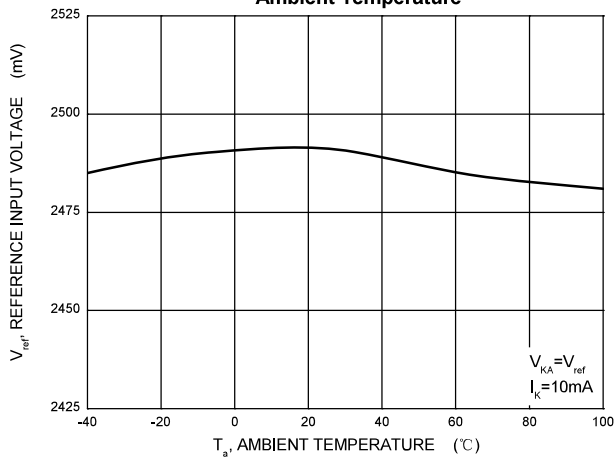

Test Circuit for $V_{KA} = V_{ref}$

Typical Characteristics

TL431

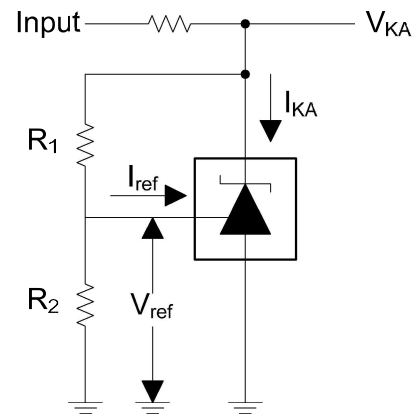
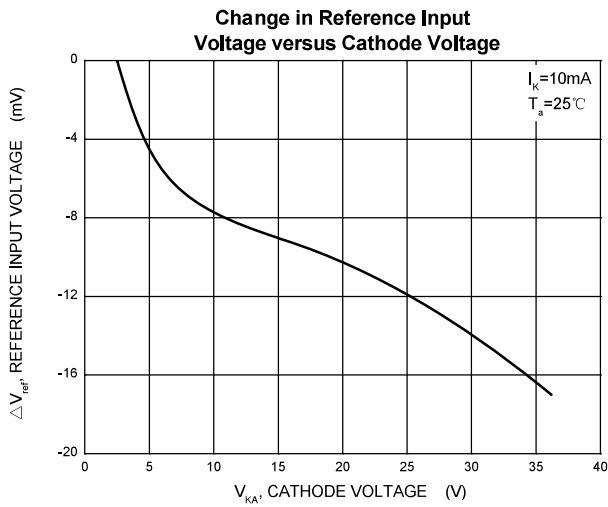

Test Circuit for $V_{KA} = V_{ref}(1 + R1/R2) + R1 * I_{ref}$

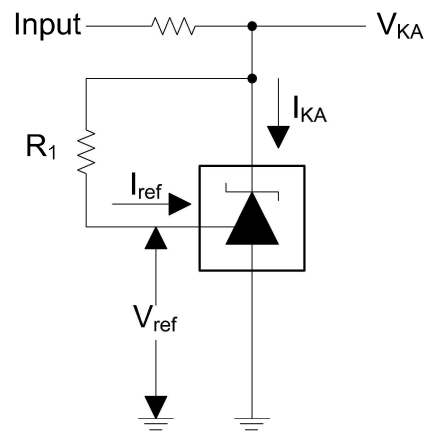
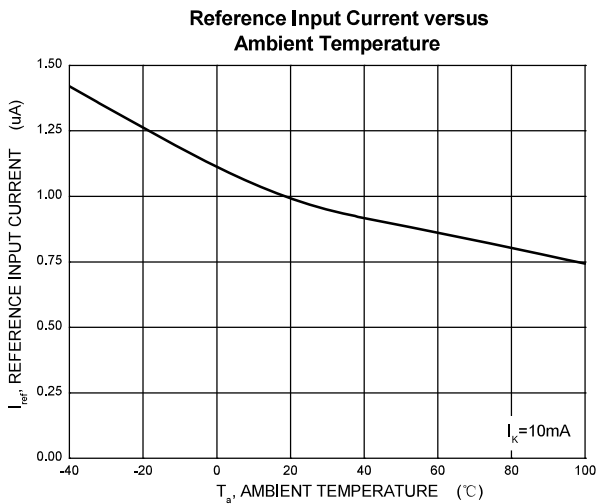

Test Circuit for I_{ref}

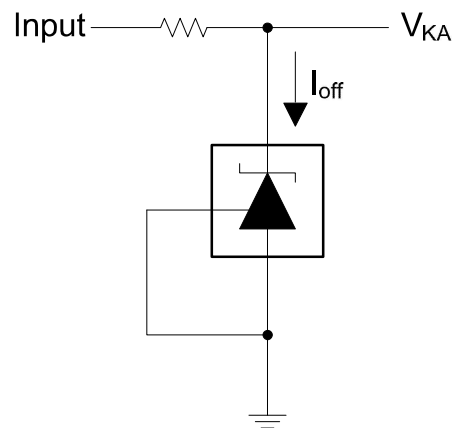
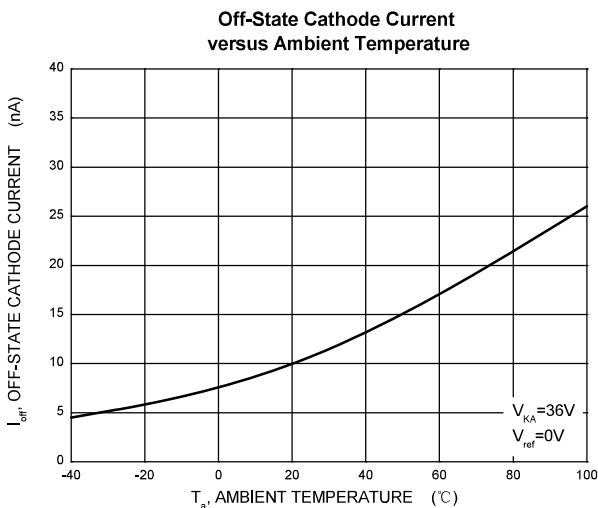

Test Circuit for I_{off}

APPLICATION INFORMATION

1. Shunt Regulator

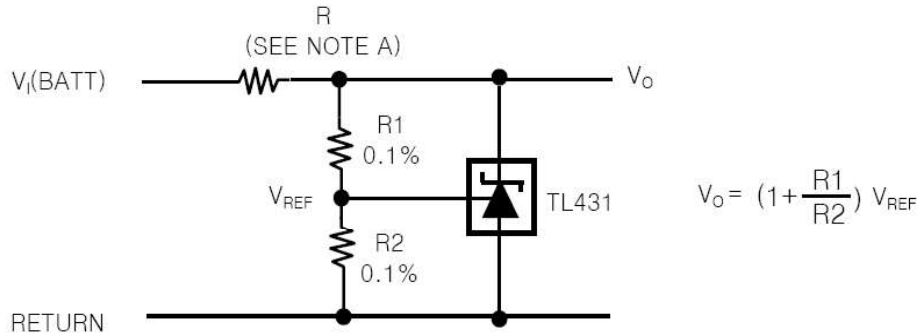

Note A : R Should provide cathode current 1mA to the TL431 at minimum $V_{I(BATT)}$

2. Output Control of a Three-Terminal Fixed Regulator

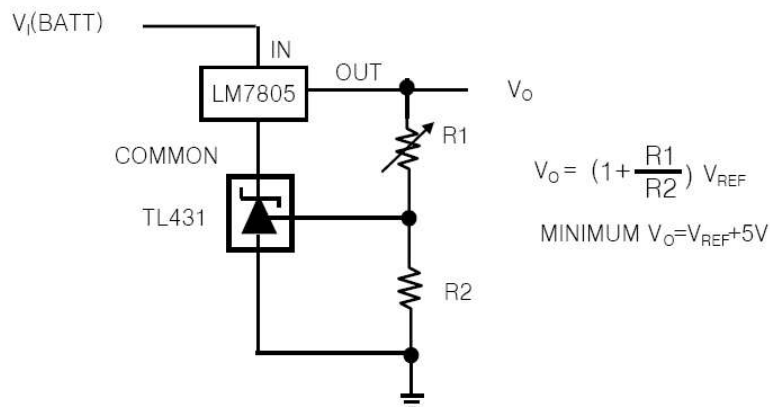

3. High-Current Shunt Regulator

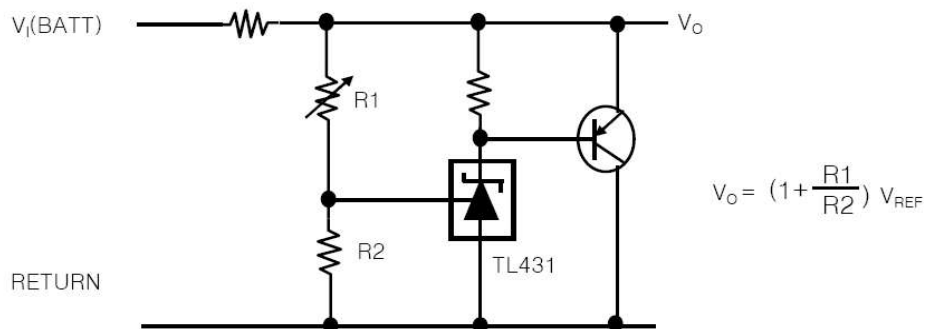

4. Efficient 5-V Precision Regulator

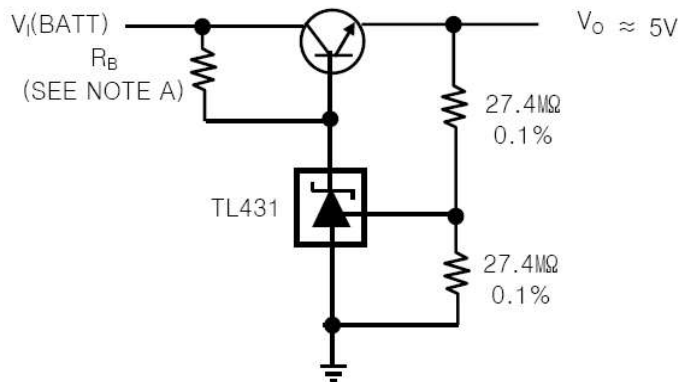

NOTE A : R_B Should provide cathode current $\geq 1\text{mA}$ to the TL431.

5. Precision Current Limiter

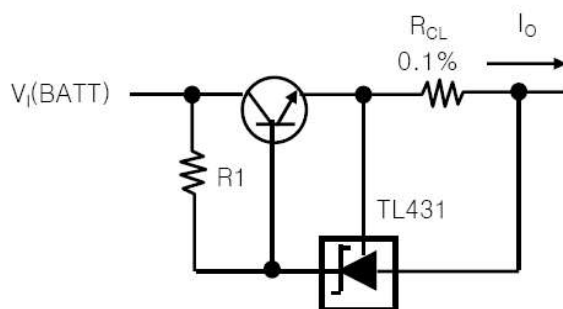

$$I_{OUT} = \frac{V_{REF}}{R_{CL}} + I_{KA}$$

$$R1 = \frac{V_I(BATT)}{I_o} + I_{KA} \frac{1}{H_{FE}}$$

6. Precision Constant-Current Sink

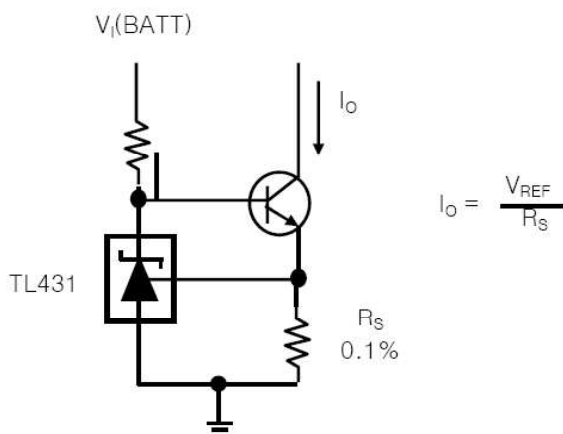

$$I_o = \frac{V_{REF}}{R_S}$$