



**DONGGUAN NANJING ELECTRONICS LTD.,**  
**TO-126 Plastic-Encapsulate Transistors**

**BD135 / BD137 / BD139** TRANSISTOR (NPN)

**FEATURES**

- High Current
- Complement To BD136, BD138 And BD140

**MARKING**

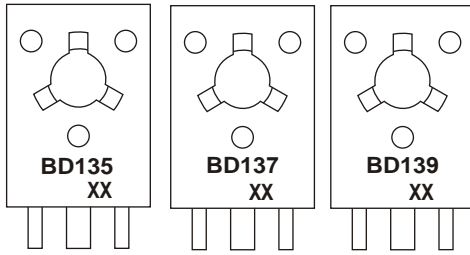

BD135, BD137, BD139 = Device code  
 XX = Code

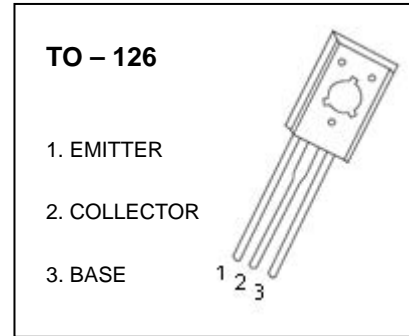

**Equivalent Circuit**

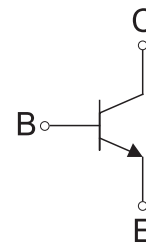

**ORDERING INFORMATION**

Part Number	Package	Packing Method	Pack Quantity
BD135	TO-126	Bulk	200pcs/Bag
BD137	TO-126	Bulk	200pcs/Bag
BD139	TO-126	Bulk	200pcs/Bag
BD135-TU	TO-126	Tube	60pcs/Tube
BD137-TU	TO-126	Tube	60pcs/Tube
BD139-TU	TO-126	Tube	60pcs/Tube

**MAXIMUM RATINGS (T<sub>a</sub>=25°C unless otherwise noted)**

Symbol	Parameter	Value	Unit
V <sub>CBO</sub>	Collector-Base Voltage	BD135	45
		BD137	60
		BD139	80
V <sub>CEO</sub>	Collector-Emitter Voltage	BD135	45
		BD137	60
		BD139	80
V <sub>EBO</sub>	Emitter-Base Voltage	5	V
I <sub>C</sub>	Collector Current	1.5	A
P <sub>C</sub>	Collector Power Dissipation	1.25	W
R <sub>θJA</sub>	Thermal Resistance From Junction To Ambient	100	°C/W
T <sub>J</sub> , T <sub>stg</sub>	Operation Junction and Storage Temperature Range	-55~+150	°C

## ELECTRICAL CHARACTERISTICS

$T_a=25\text{ }^\circ\text{C}$  unless otherwise specified

Parameter	Symbol	Test conditions	Min	Typ	Max	Unit
<b>Collector-base breakdown voltage</b> BD135 BD137 BD139	$V_{(BR)CBO}$	$I_C=0.1\text{mA}, I_E=0$	45 60 80			V
<b>Collector-emitter sustaining voltage</b> BD135 BD137 BD139	$V_{CEO(SUS)}$ *	$I_C=0.03\text{A}, I_B=0$	45 60 80			V
<b>Emitter-base breakdown voltage</b>	$V_{(BR)EBO}$	$I_E=0.1\text{mA}, I_C=0$	5			V
<b>Collector cut-off current</b>	$I_{CBO}$	$V_{CB}=30\text{V}, I_E=0$			0.1	$\mu\text{A}$
<b>Emitter cut-off current</b>	$I_{EBO}$	$V_{EB}=5\text{V}, I_C=0$			10	$\mu\text{A}$
<b>DC current gain</b>	$h_{FE(1)}$ *	$V_{CE}=2\text{V}, I_C=150\text{mA}$	40		250	
	$h_{FE(2)}$ *	$V_{CE}=2\text{V}, I_C=5\text{mA}$	25			
	$h_{FE(3)}$ *	$V_{CE}=2\text{V}, I_C=500\text{mA}$	25			
<b>Collector-emitter saturation voltage</b>	$V_{CE(sat)}$ *	$I_C=500\text{mA}, I_B=50\text{mA}$			0.5	V
<b>Base-emitter voltage</b>	$V_{BE}$ *	$V_{CE}=2\text{V}, I_C=500\text{mA}$			1	V

\*Pulse test: pulse width  $\leq 350\mu\text{s}$ , duty cycle  $\leq 2.0\%$ .

### CLASSIFICATION OF $h_{FE(1)}$

<b>RANK</b>	<b>6</b>	<b>10</b>	<b>16</b>
<b>RANGE</b>	40-100	63-160	100-250

# Typical Characteristics

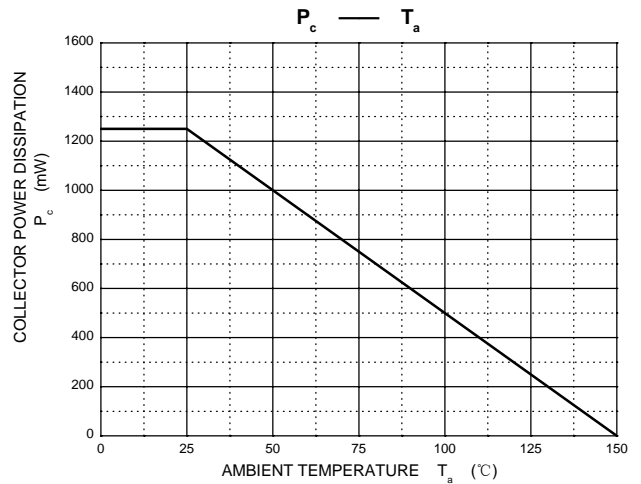
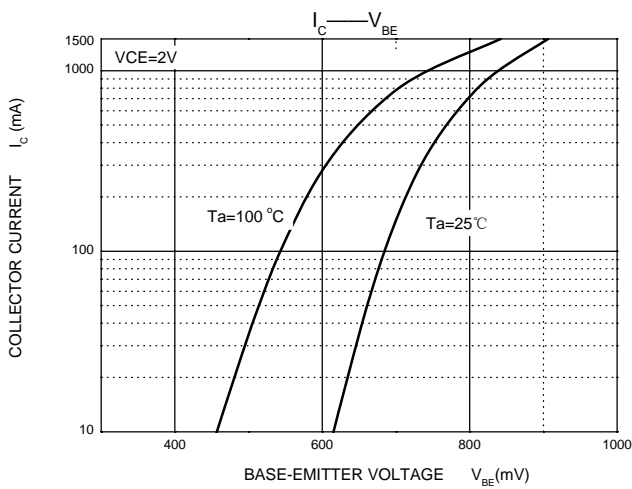
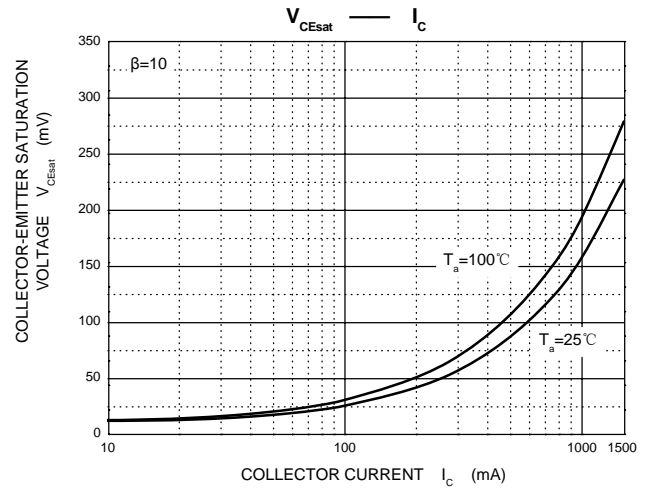
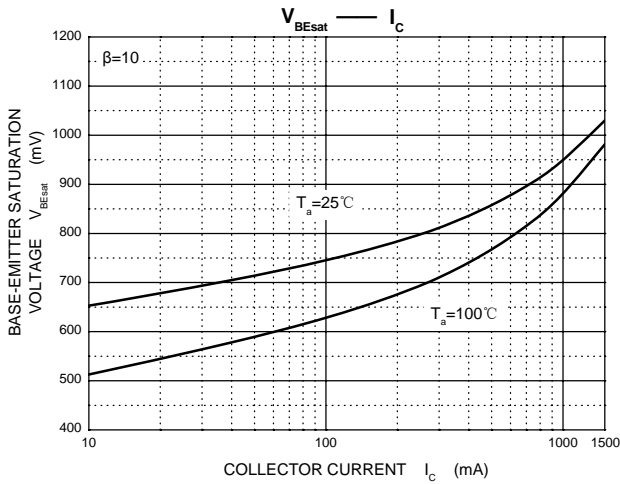
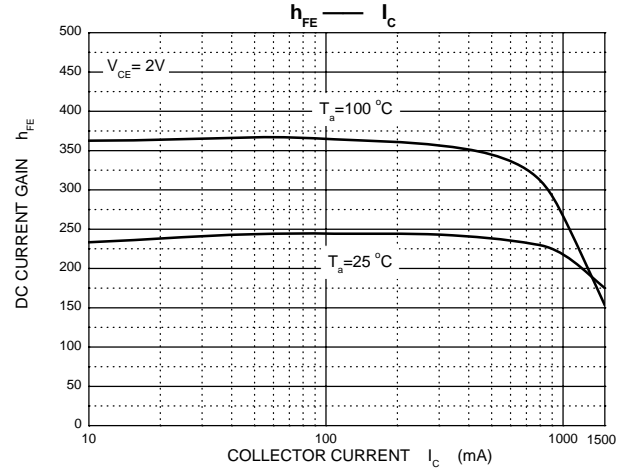
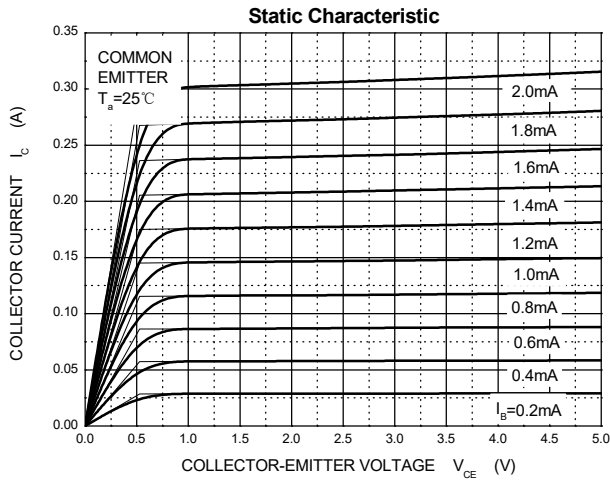

# TO-126 Package Outline Dimensions



Symbol	Dimensions In Millimeters		Dimensions In Inches	
	Min	Max	Min	Max
A	2.500	2.900	0.098	0.114
A1	1.100	1.500	0.043	0.059
b	0.660	0.860	0.026	0.034
b1	1.170	1.370	0.046	0.054
c	0.450	0.600	0.018	0.024
D	7.400	7.800	0.291	0.307
E	10.600	11.000	0.417	0.433
e	2.290 TYP		0.090 TYP	
e1	4.480	4.680	0.176	0.184
h	0.000	0.300	0.000	0.012
L	15.300	15.700	0.602	0.618
L1	2.100	2.300	0.083	0.091
P	3.900	4.100	0.154	0.161
$\phi$	3.000	3.200	0.118	0.126