



TO-220-3L Plastic-Encapsulate Transistors

2SA1012 TRANSISTOR (PNP)

FEATURES

- High Current Switching Applications
- Low Collector Saturation Voltage
- High Speed Switching Time

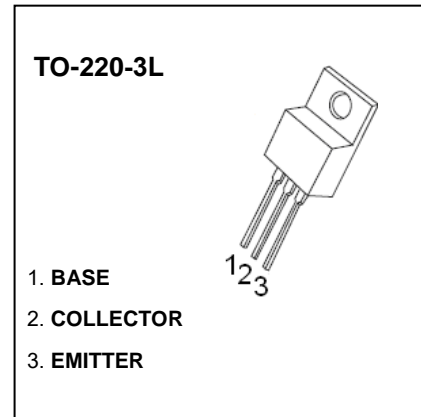

MARKING

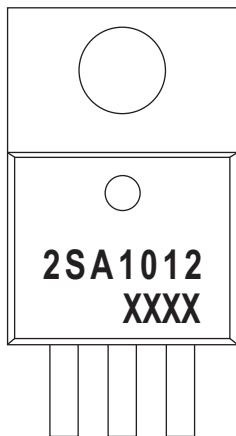

2SA1012=Device code
XXXX=Code

Equivalent Circuit

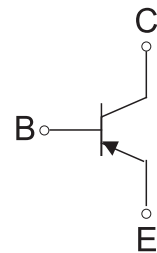

MAXIMUM RATINGS ($T_a=25^{\circ}\text{C}$ unless otherwise noted)

Symbol	Parameter	Value	Unit
V_{CBO}	Collector-Base Voltage	-60	V
V_{CEO}	Collector-Emitter Voltage	-50	V
V_{EBO}	Emitter-Base Voltage	-5	V
I_C	Collector Current -Continuous	-5	A
P_C	Collector Power Dissipation	2	W
$R_{\theta JA}$	Thermal Resistance Junction to Ambient	62.5	$^{\circ}\text{C}/\text{W}$
T_J, T_{stg}	Operation Junction and Storage Temperature Range	-55~+150	$^{\circ}\text{C}$

ELECTRICAL CHARACTERISTICS(T_a=25°C unless otherwise specified)

Parameter	Symbol	Test conditions	Min	Typ	Max	Unit
Collector-base breakdown voltage	V _{(BR)CBO}	I _C = -0.1mA, I _E = 0	-60			V
Collector-emitter breakdown voltage	V _{(BR)CEO} *	I _C = -10mA, I _B = 0	-50			V
Emitter-base breakdown voltage	V _{(BR)EBO}	I _E = -100μA, I _C = 0	-5			V
Collector cut-off current	I _{CBO}	V _{CB} = -50V, I _E = 0			-1	μA
Emitter cut-off current	I _{EBO}	V _{EB} = -5V, I _C = 0			-1	μA
DC current gain	h _{FE(1)}	V _{CE} = -1V, I _C = -1A	70		240	
	h _{FE(2)} *	V _{CE} = -1V, I _C = -3A	30			
Collector-emitter saturation voltage	V _{CE(sat)} *	I _C = -3A, I _B = -150mA			-0.4	V
Base-emitter saturation voltage	V _{BE(sat)} *	I _C = -3A, I _B = -150mA			-1.2	V
Transition frequency	f _T	V _{CE} = -4V, I _C = -1A		60		MHz
Collector output capacitance	C _{ob}	V _{CB} = -10V, I _E = 0, f = 1MHz		170		pF
Turn-on Time	t _{on}	V _{CC} = -30V, I _C = -3A, I _{B1} = -I _{B2} = -0.15A		0.1		μs
Storage Time	t _s			1.0		
Fall Time	t _f			0.1		

*Pulse test: t_p ≤ 300μs, δ ≤ 0.02.

CLASSIFICATION of h_{FE(1)}

Rank	O	Y
Range	70-140	120-240

Typical Characteristics

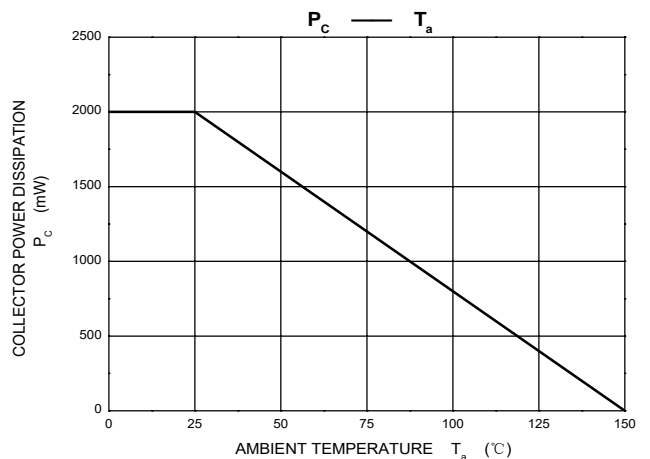
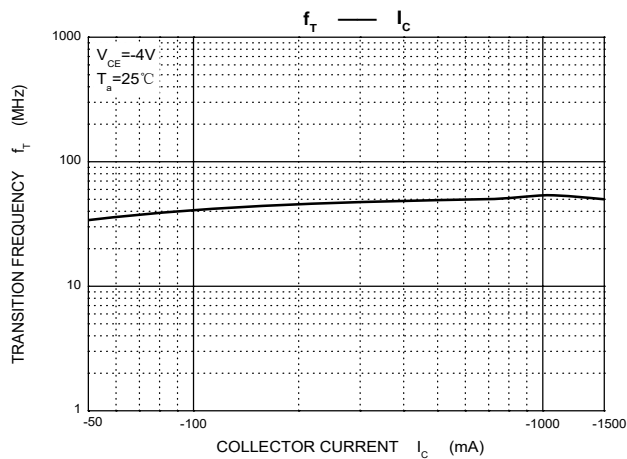
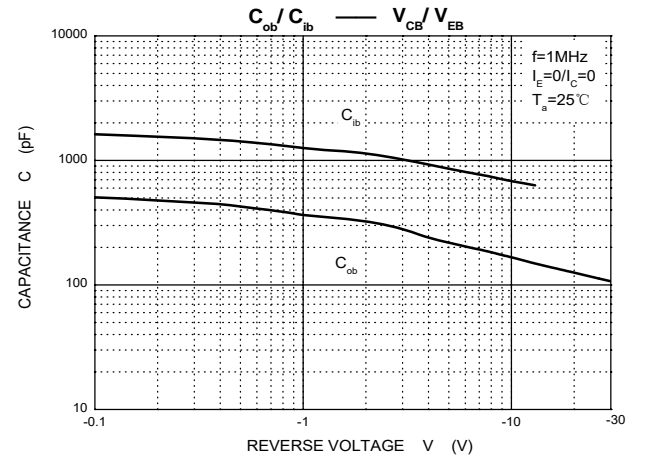
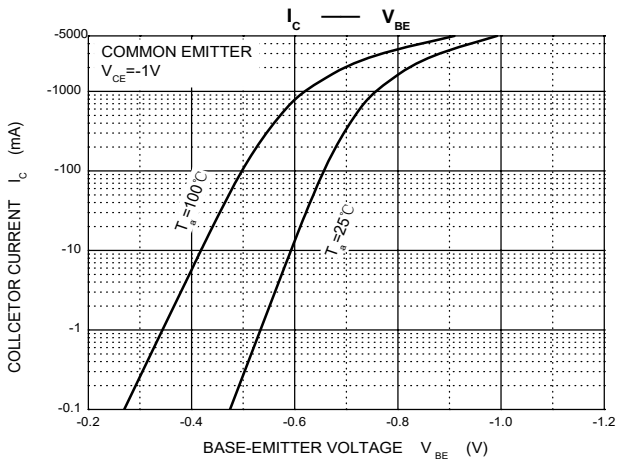
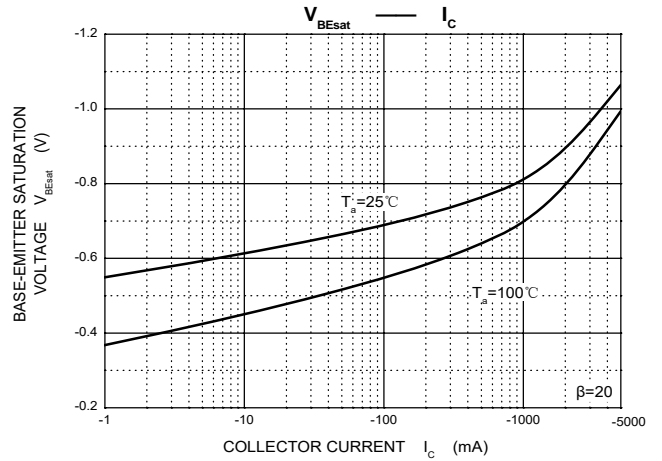
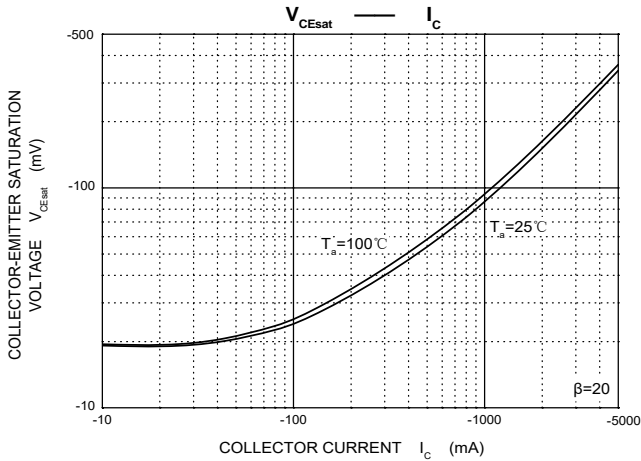
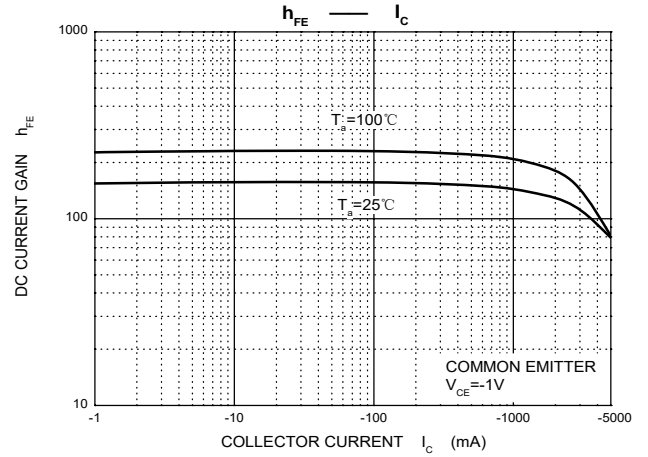
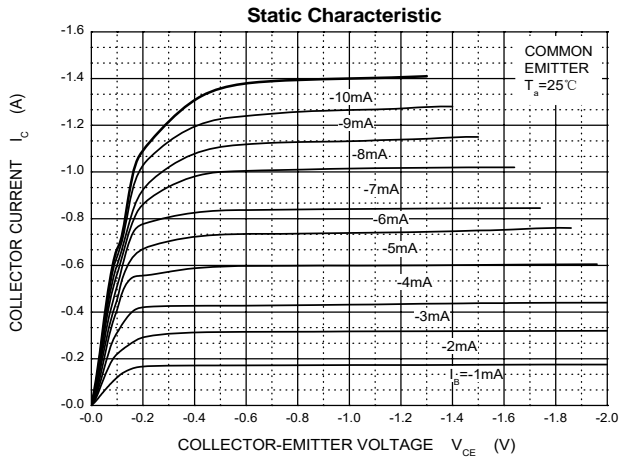

TO-220-3L Package Outline Dimensions

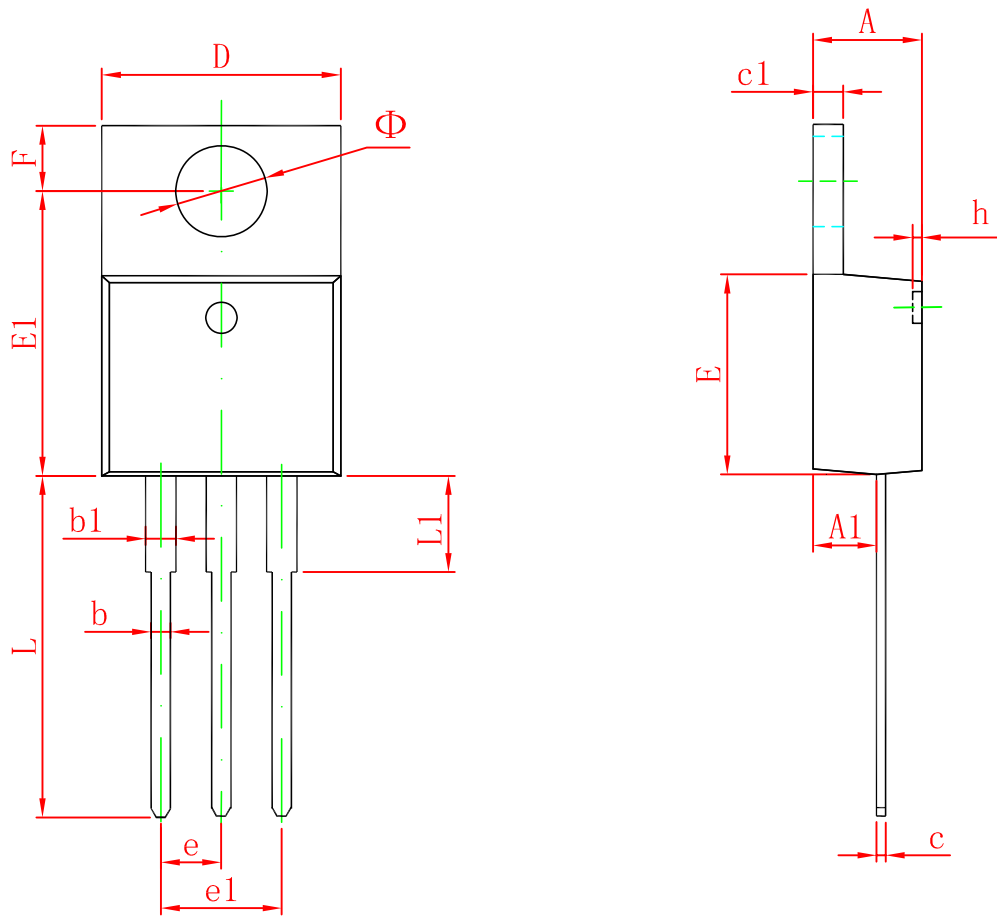

Symbol	Dimensions In Millimeters		Dimensions In Inches	
	Min	Max	Min	Max
A	4.470	4.670	0.176	0.184
A1	2.520	2.820	0.099	0.111
b	0.710	0.910	0.028	0.036
b1	1.170	1.370	0.046	0.054
c	0.310	0.530	0.012	0.021
c1	1.170	1.370	0.046	0.054
D	10.010	10.310	0.394	0.406
E	8.500	8.900	0.335	0.350
E1	12.060	12.460	0.475	0.491
e	2.540 TYP		0.100 TYP	
e1	4.980	5.180	0.196	0.204
F	2.590	2.890	0.102	0.114
h	0.000	0.300	0.000	0.012
L	13.400	13.800	0.528	0.543
L1	3.560	3.960	0.140	0.156
Φ	3.735	3.935	0.147	0.155