



DONGGUAN NANJING ELECTRONICS LTD.,
SMA Plastic-Encapsulate Diodes

SS12L THRU SS120L Schottky Rectifier Diodes

Features

- $I_{F(AV)}$ 1A
- V_{RRM} 20V-200V
- High surge current capability
- Polarity: Color band denotes cathode

Applications

- Rectifier

Marking

- SS1X
- X : From 2L To 20L

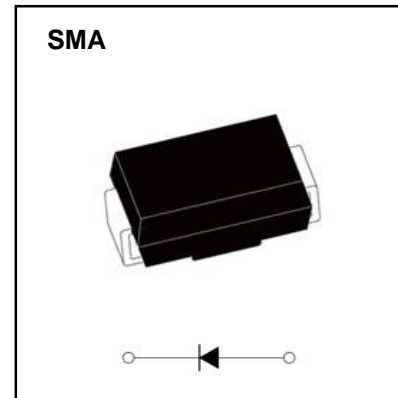

Limiting Values(Absolute Maximum Rating)

Item	Symbol	Unit	Test Conditions	SS1																
				2L	3L	4L	5L	6L	8L	10L	15L	20L								
Repetitive Peak Reverse Voltage	V_{RRM}	V		20	30	40	50	60	80	100	150	200								
Maximum RMS Voltage	V_{RMS}	V		14	21	28	35	42	56	70	105	140								
Average Forward Current	$I_{F(AV)}$	A	60Hz Half-sine wave, Resistance load, $T_a=100^\circ\text{C}$	1.0																
Surge(Non-repetitive)Forward Current	I_{FSM}	A	60Hz Half-sine wave, 1 cycle, $T_a=25^\circ\text{C}$	30																
Junction Temperature	T_J	$^\circ\text{C}$		-55~+150																
Storage Temperature	T_{STG}	$^\circ\text{C}$		-55 ~ +150																

Electrical Characteristics ($T = 25^\circ\text{C}$ Unless otherwise specified)

Item	Symbol	Unit	Test Condition	SS1																
				2L	3L	4L	5L	6L	8L	10L	15L	20L								
Peak Forward Voltage	V_F	V	$I_F=1.0A$	0.45		0.58		0.75		0.85										
Peak Reverse Current	I_{RRM1}	mA	$V_{RM}=V_{RRM}$	$T_a=25^\circ\text{C}$		0.2		0.1												
	I_{RRM2}			$T_a=100^\circ\text{C}$		10		5.0												
Thermal Resistance(Typical)	$R_{\theta J-A}$	$^\circ\text{C}/\text{W}$	Between junction and ambient		75															
	$R_{\theta J-L}$		Between junction and terminal		17															

Notes:

Thermal resistance from junction to ambient and from junction to lead mounted on P.C.B. with 0.2" x 0.2" (5.0 mm x 5.0 mm) copper pad areas

Typical Characteristics

FIG.1: FORWARD CURRENT DERATING CURVE

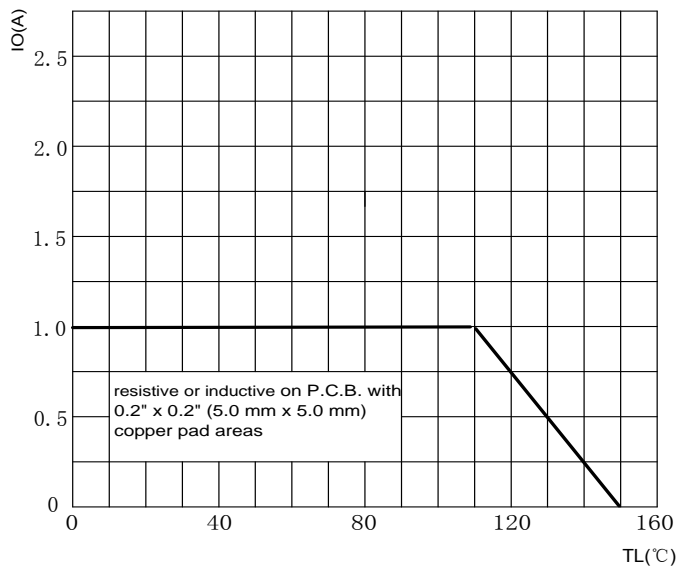

FIG.2: MAXIMUM NON-REPETITIVE FORWARD SURGE CURRENT

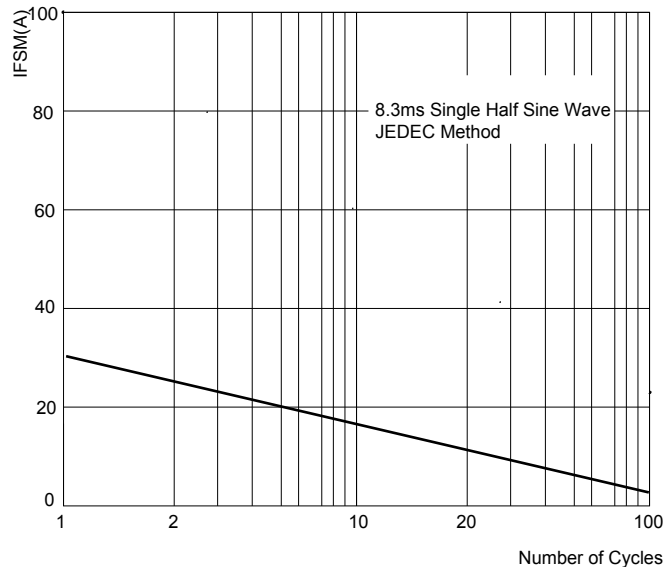

FIG.3: TYPICAL FORWARD CHARACTERISTICS

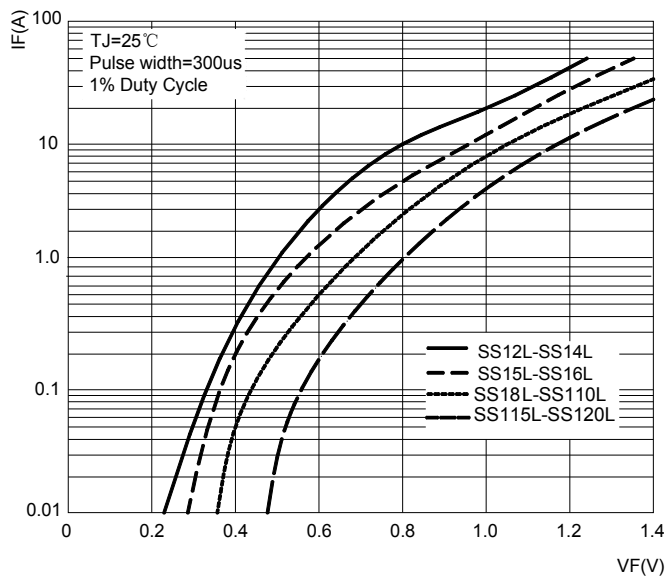
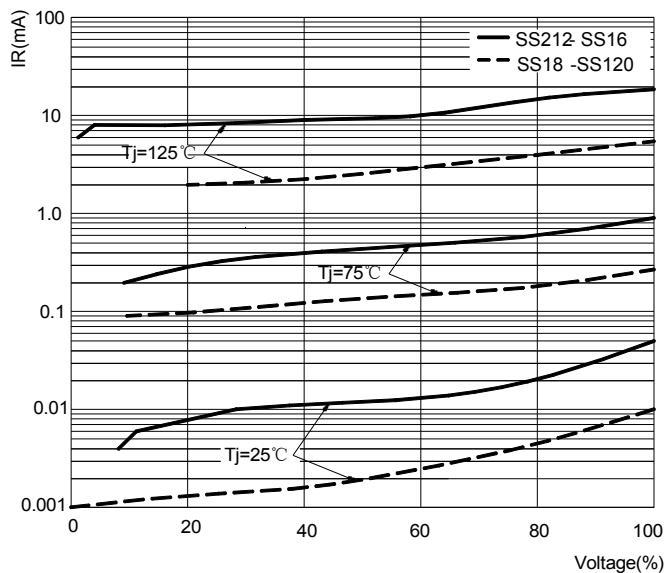
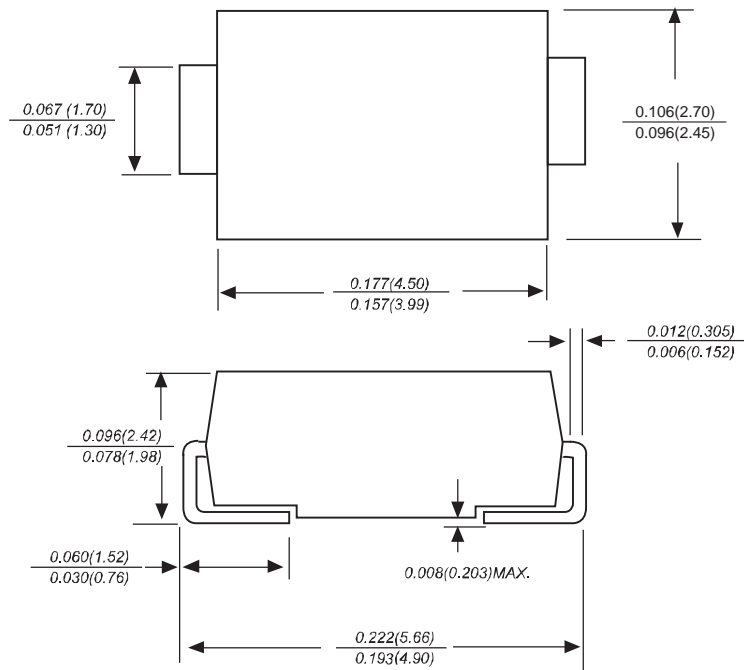

FIG.4: TYPICAL REVERSE CHARACTERISTICS



SMA Package Outline Dimensions



Dimensions in inches and (millimeters)

SMA Suggested Pad Layout

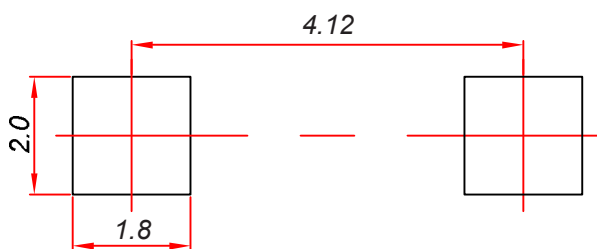

Note:

1. Controlling dimension: in millimeters.
2. General tolerance: ± 0.05 mm.
3. The pad layout is for reference purposes only.

Reel Taping Specifications For Surface Mount Devices- SMA

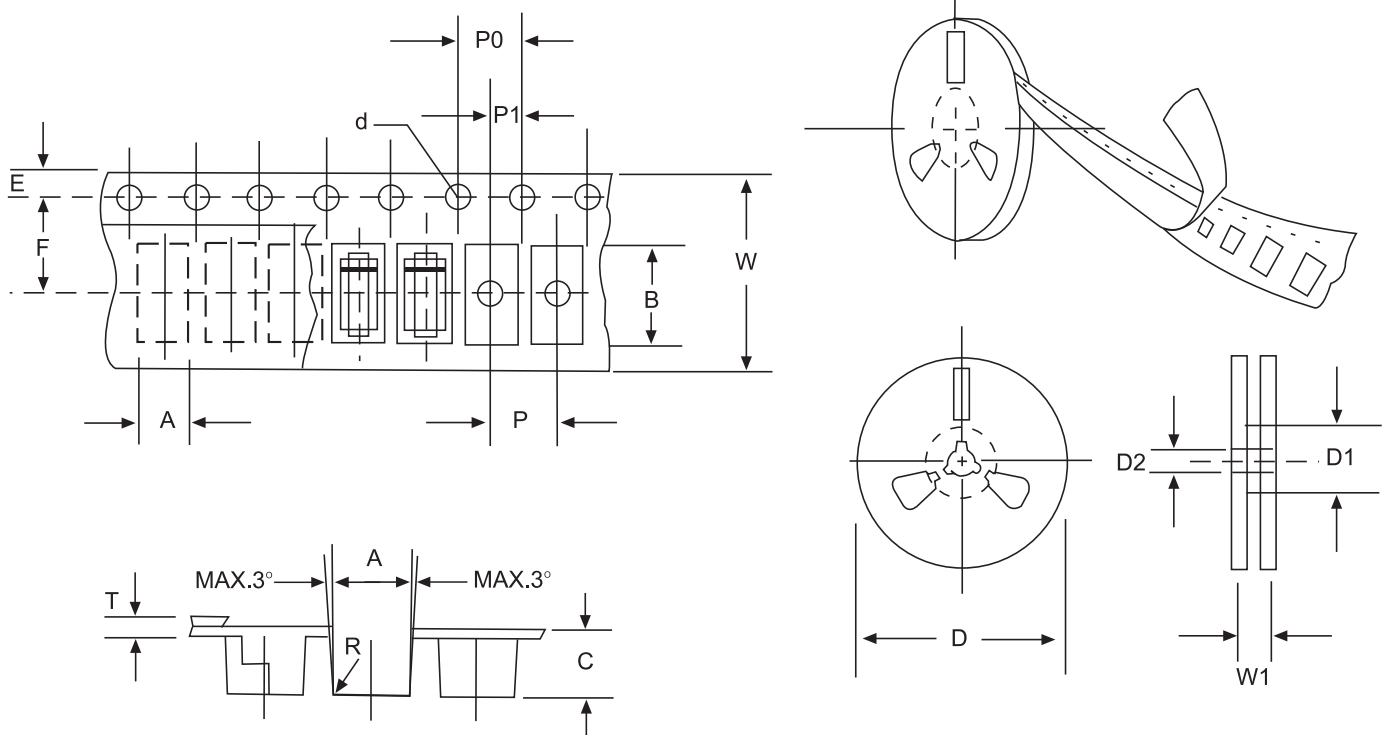

FIG: CONFIGURATION OF SURFACE MOUNTED DEVICES TAPING

ITEM	SYMBOL	SMA mm(inch)
Carrier width	A	2.79±0.1(0.110±0.004)
Carrier length	B	5.33±0.1(0.210±0.004)
Carrier depth	C	2.36±0.1(0.093±0.004)
Sprocket hole	d	1.55±0.05(0.061±0.002)
Reel outside diameter	D	279±2.0 (11± 0.079)
Reel inner diameter	D1	75 ±1.0 (2.95 ±0.039)
Feed hole diameter	D2	13±0.5(0.512±0.020)
Sprocket hole position	E	1.75±0.1(0.069±0.004)
Punch hole position	F	5.5±0.05(0.217±0.002)
Punch hole pitch	P	4.0±0.1(0.157±0.004)
Sprocket hole pitch	P0	4.0±0.1(0.157±0.004)
Embossment center	P1	2.0±0.1(0.079±0.004)
Total tape thickness	T	0.28±0.02(0.011±0.0008)
Tape width	W	12.0±0.2(0.472±0.008)
Reel width	W1	16.8±2.0(0.661±0.079)

NOTE: Devices are packed in accordance with EIA standard RS-481-A and specification given above.