



DONGGUAN NANJING ELECTRONICS LTD.,

TO-220AB/ITO-220AB Plastic-Encapsulate Diode

MUR1640CT、MURF1640CT SUPER FAST RECOVER RECTIFIER

MAIN CHARACTERISTICS

I_o	16A
V_{RRM}	400 V
T_j	150 °C
$V_{F(typ)}$	1.1V (@ $T_j=125^{\circ}C$)

FEATURES

- Ultrafast 35ns Recovery Times
- High Voltage Capability to 400V
- Low Reverse Leakage Current

MARKING

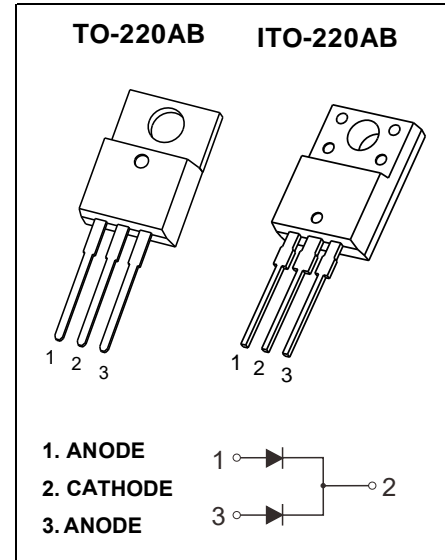
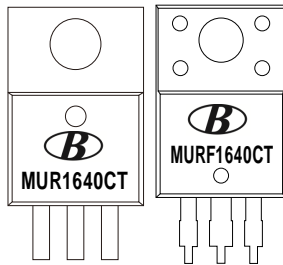

MAXIMUM RATINGS ($T_a=25^{\circ}C$ unless otherwise noted)

Symbol	Parameter	MUR		Unit
		1640CT	F1640CT	
V_{RRM}	Peak repetitive reverse voltage	400		V
V_{RWM}	Working peak reverse voltage			
V_R	DC blocking voltage			
$V_{R(RMS)}$	RMS reverse voltage	280		V
I_o	Average rectified output current@ Per leg	8		A
	Average rectified output current@ Total device	16		A
I_{FSM}	Non-Repetitive peak forward surge current 8.3ms half sine wave	125		A
$R_{\theta Jc}$	Thermal resistance from junction to case , $T_c=25^{\circ}C$	3.5		$^{\circ}C/W$
$R_{\theta JA}$	Thermal resistance from junction to ambient	62.5		$^{\circ}C/W$
T_j	Operating Junction Temperature Range	-55 ~ +150		$^{\circ}C$
T_{stg}	Storage Temperature Range	-55 ~ +150		$^{\circ}C$

ELECTRICAL CHARACTERISTICS ($T_a=25^{\circ}C$ unless otherwise specified)

Parameter	Symbol	Test conditions	Min	Typ	Max	Unit
Reverse voltage	$V_{(BR)}$	$I_R=100\mu A$	400			V
Reverse current	I_R	$V_R=400V$	$T_j = 25^{\circ}C$	0.1	1	μA
			$T_j = 125^{\circ}C$	1.0	10	μA
Forward voltage	V_F	$I_F=8.0A$	$T_j = 25^{\circ}C$	1.22	1.30	V
			$T_j = 125^{\circ}C$	1.10		V
Typical total capacitance	C_{tot}	$V_R=4.0V, f=1MHz$		28		pF
Reverse recovery time	t_{rr}	$I_F=0.5A, I_R=1A, I_{tr}=0.25A$			35	ns

Typical Characteristics

Forward Characteristics

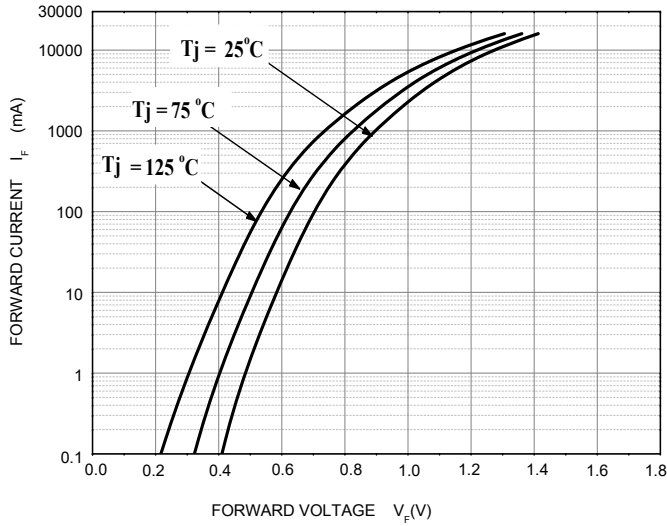

Reverse Characteristics

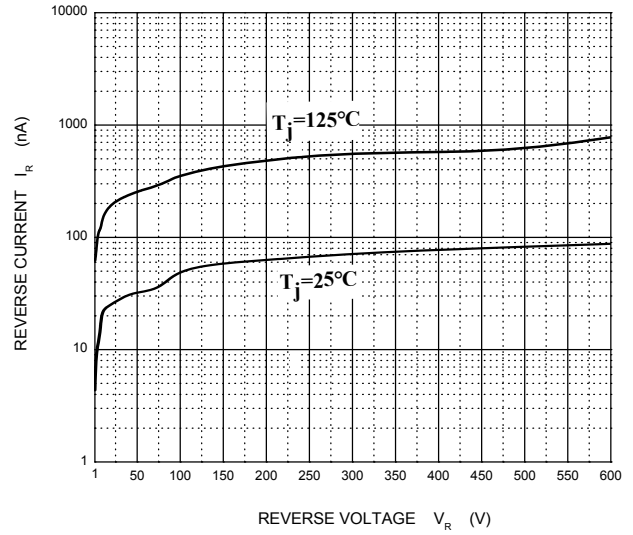

Capacitance Characteristics

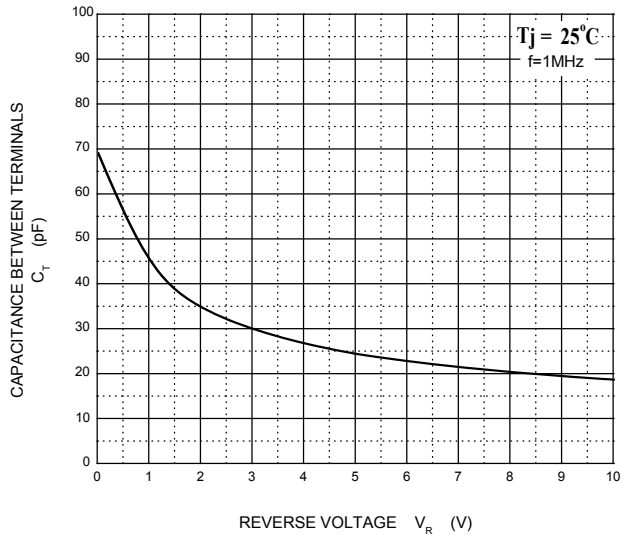

FORWARD CURRENT DERATING CURVE

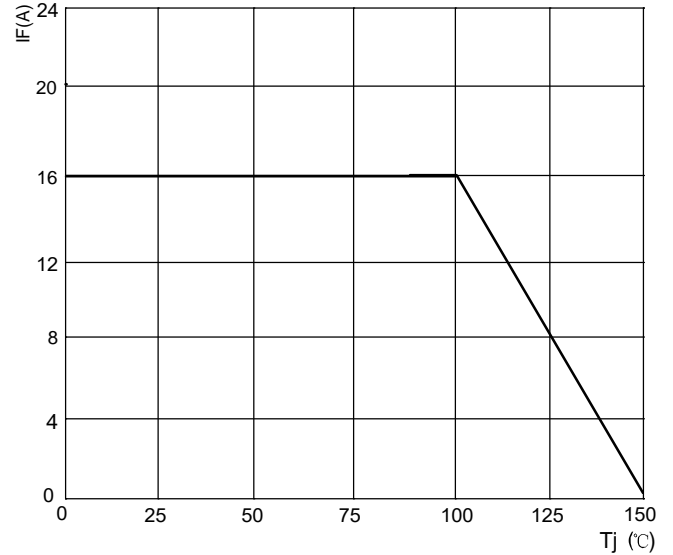
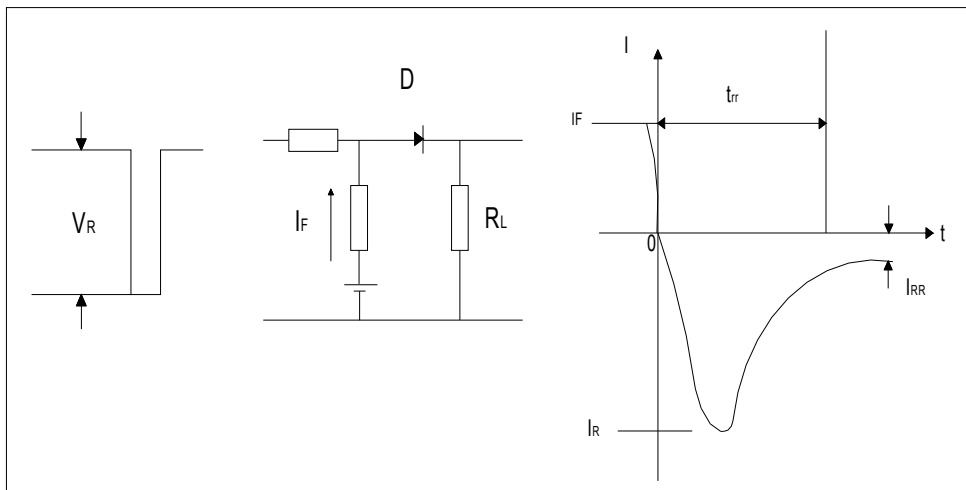
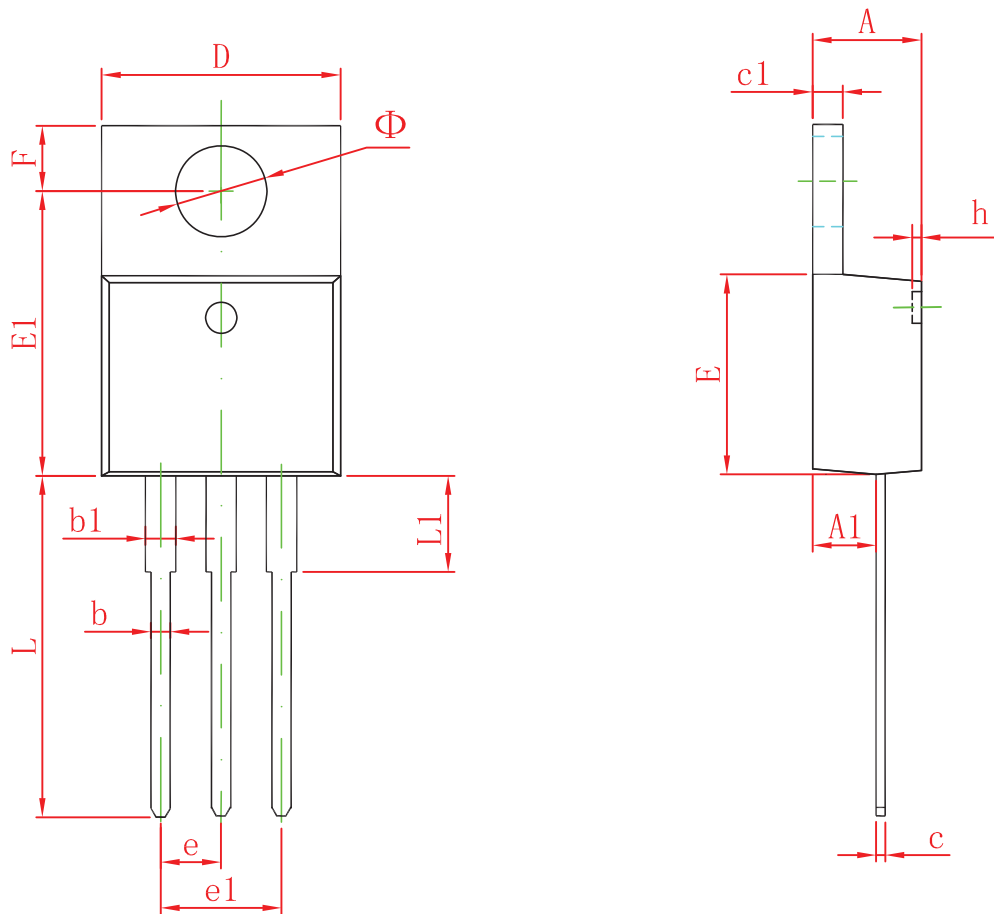

Diagram of circuit and Testing wave form of reverse recovery time



TO-220AB Package Outline Dimensions



Symbol	Dimensions In Millimeters		Dimensions In Inches	
	Min	Max	Min	Max
A	4.450	4.750	0.175	0.187
A1	2.520	2.820	0.099	0.111
b	0.710	0.910	0.028	0.036
b1	1.170	1.370	0.046	0.054
c	0.300	0.500	0.012	0.020
c1	1.170	1.370	0.046	0.054
D	9.830	10.330	0.387	0.407
E	8.500	8.900	0.335	0.350
E1	12.050	12.650	0.474	0.498
e	2.540 TYP		0.100 TYP	
e1	4.900	5.200	0.192	0.205
F	2.540	2.940	0.100	0.116
h	0.100 TYP		0.004 TYP	
L	13.300	13.800	0.523	0.543
L1	3.540	3.940	0.139	0.155
Φ	3.735	3.935	0.147	0.155

ITO-220AB Package Outline Dimensions

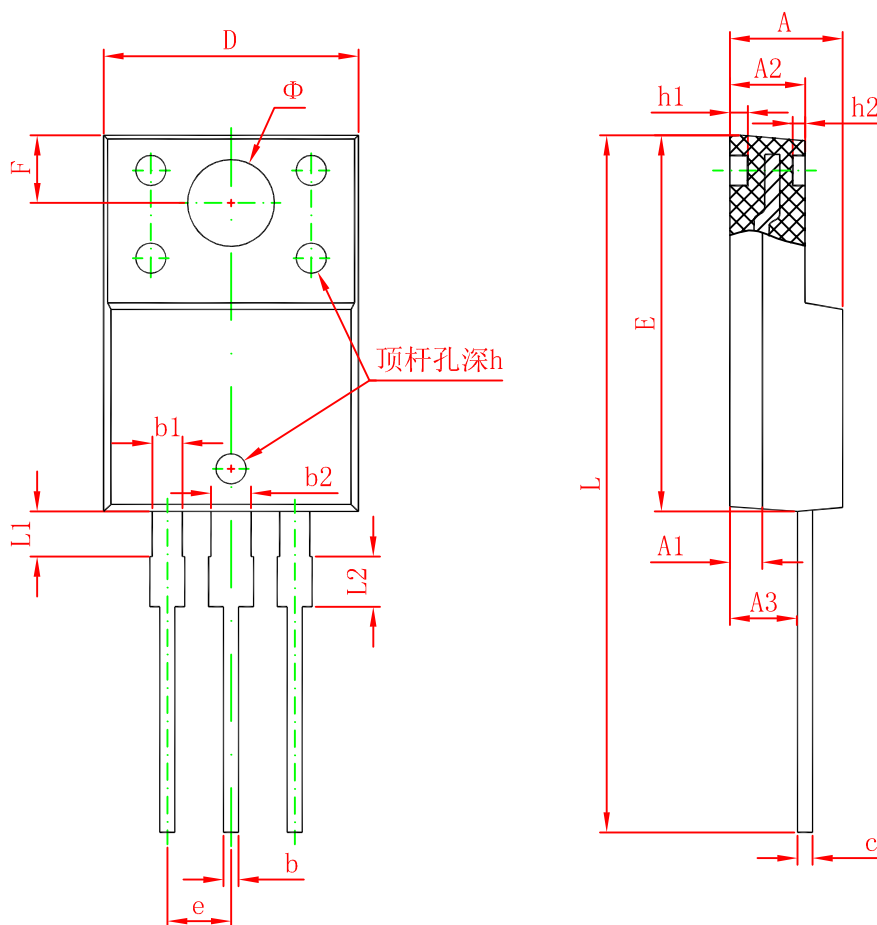

Symbol	Dimensions In Millimeters		Dimensions In Inches	
	Min.	Max.	Min.	Max.
A	4.300	4.700	0.169	0.185
A1	1.300 REF.		0.051 REF.	
A2	2.800	3.200	0.110	0.126
A3	2.500	2.900	0.098	0.114
b	0.500	0.750	0.020	0.030
b1	1.100	1.350	0.043	0.053
b2	1.500	1.750	0.059	0.069
c	0.500	0.750	0.020	0.030
D	9.960	10.360	0.392	0.408
E	14.800	15.200	0.583	0.598
e	2.540 TYP.		0.100 TYP.	
F	2.700 REF.		0.106 REF.	
Φ	3.500 REF.		0.138 REF.	
h	0.000	0.300	0.000	0.012
h1	0.800 REF.		0.031 REF.	
h2	0.500 REF.		0.020 REF.	
L	28.000	28.400	1.102	1.118
L1	1.700	1.900	0.067	0.075
L2	1.900	2.100	0.075	0.083