



DONGGUAN NANJING ELECTRONICS LTD.,
SOD-123 Plastic-Encapsulate Diodes

BAS16W FAST SWITCHING DIODE

FEATURES

- Fast Switching Speed
- Surface Mount Package Ideally Suited for Automatic Insertion
- For General Purpose Switching Applications
- High Conductance

MARKING:

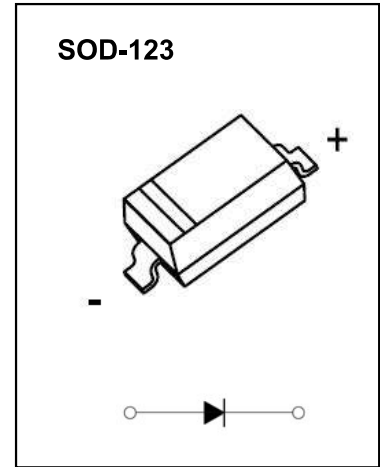

Maximum Ratings and Electrical Characteristics, Single Diode @T_a=25°C

Parameter	Symbol	Limit	Unit
Non-Repetitive Peak Reverse Voltage	V _{RM}	100	V
Peak Repetitive Peak Reverse Voltage	V _{RRM}		
Working Peak Reverse Voltage	V _{RWM}	100	V
DC Blocking Voltage	V _R		
RMS Reverse Voltage	V _{R(RMS)}	75	V
Forward Continuous Current	I _{FM}	500	mA
Average Rectified Output Current	I _O	250	mA
Non-Repetitive Peak Forward Surge Current @t=8.3ms	I _{FSM}	2.0	A
Power Dissipation	P _d	400	mW
Thermal Resistance from Junction to Ambient(Note 1)	R _{θJA}	312.5	°C/W
Operation Junction and Storage Temperature Range	T _J , T _{STG}	-55~+150	°C

Note 1: Device mounted on 1"x1" FR4 PCB, 1oz single-side copper.

ELECTRICAL CHARACTERISTICS

Electrical Ratings @Ta=25°C

Parameter	Symbol	Min	Typ	Max	Unit	Conditions
Forward voltage	V_{F1}			0.715	V	$I_F=10\text{mA}$
	V_{F2}			0.855	V	$I_F=50\text{mA}$
	V_{F3}			1.0	V	$I_F=150\text{mA}$
	V_{F4}			1.25	V	$I_F=225\text{mA}$
Reverse current	I_{R1}			1	μA	$V_R=85\text{V}$
	I_{R2}			25	nA	$V_R=20\text{V}$
Capacitance between terminals	C_T			2	pF	$V_R=0\text{V}, f=1\text{MHz}$
Reverse recovery time	t_{rr}			4	ns	$I_F=I_R=10\text{mA}$ $I_{rr}=0.1I_R, R_L=100\Omega$

Typical Characteristics

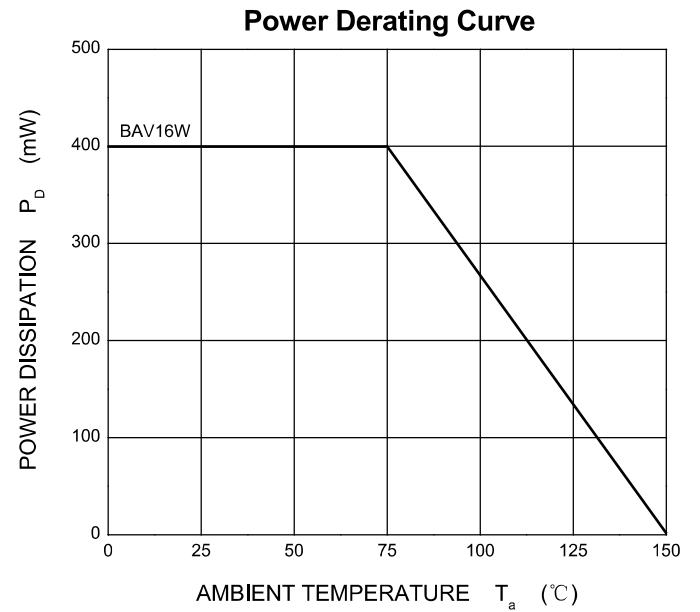
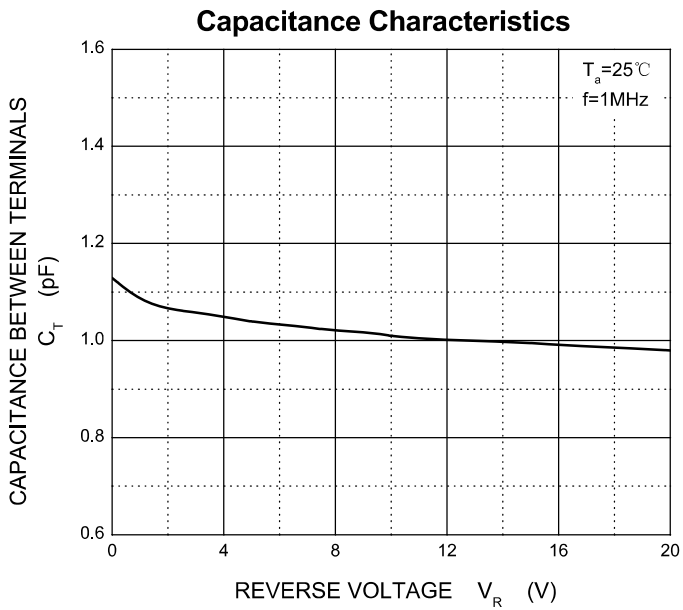
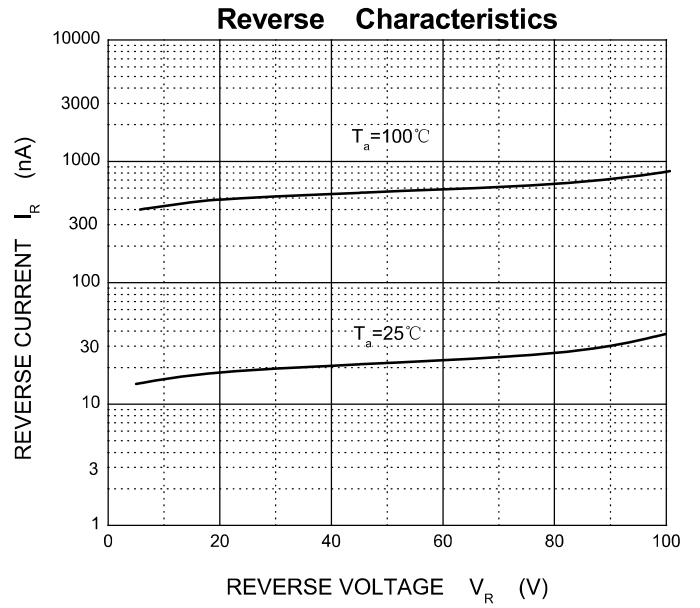
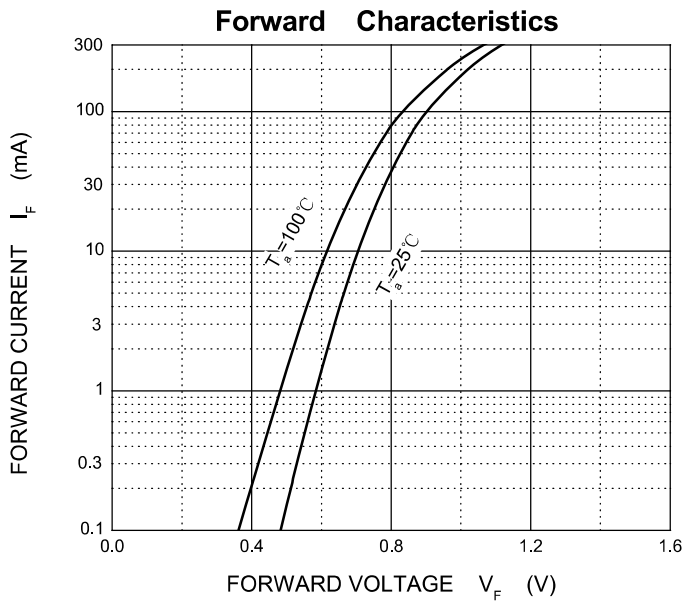

SOD-123 Package Outline Dimensions

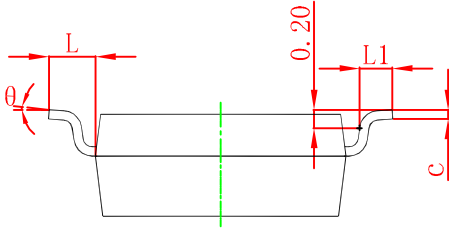
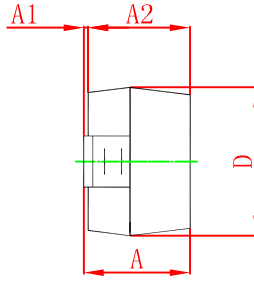
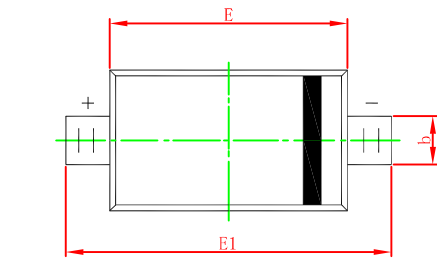

Symbol	Dimensions In Millimeters		Dimensions In Inches	
	Min	Max	Min	Max
A	1.050	1.250	0.041	0.049
A1	0.000	0.100	0.000	0.004
A2	1.050	1.150	0.041	0.045
b	0.450	0.650	0.018	0.026
c	0.080	0.150	0.003	0.006
D	1.500	1.700	0.059	0.067
E	2.600	2.800	0.102	0.110
E1	3.550	3.850	0.140	0.152
L	0.500 REF		0.020 REF	
L1	0.250	0.450	0.010	0.018
θ	0°	8°	0°	8°

SOD-123 Suggested Pad Layout

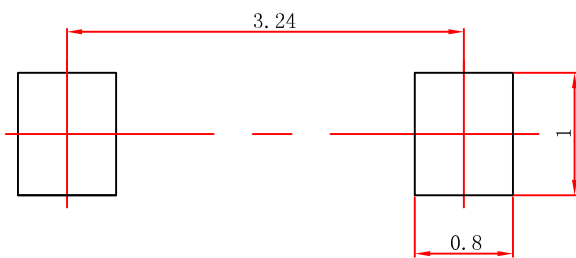

Note:

1. Controlling dimension: in millimeters.
2. General tolerance: $\pm 0.05\text{mm}$.
3. The pad layout is for reference purposes only.

SOD-123 Tape and Reel

SOD-123 Embossed Carrier Tape

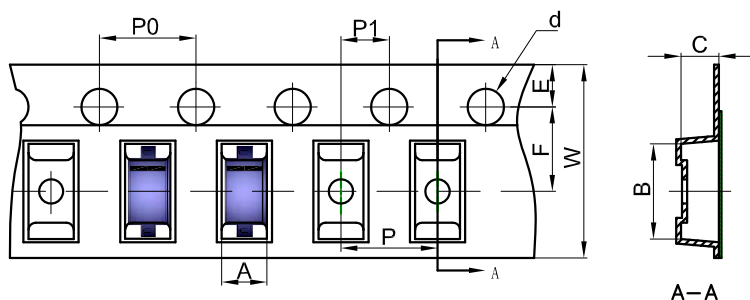

Packaging Description:

SOD-123 parts are shipped in tape. The carrier tape is made from a dissipative (carbon filled) polycarbonate resin. The cover tape is a multilayer film (Heat Activated Adhesive in nature) primarily composed of polyester film, adhesive layer, sealant, and anti-static sprayed agent. These reeled parts in standard option are shipped with 3,000 units per 7" or 17.8cm diameter reel. The reels are clear in color and is made of polystyrene plastic (anti-static coated).

Dimensions are in millimeter

Pkg type	A	B	C	d	E	F	P0	P	P1	W
SOD-123	1.85	3.95	1.57	Ø1.55	1.75	3.50	4.00	4.00	2.00	8.00

SOD-123 Tape Leader and Trailer

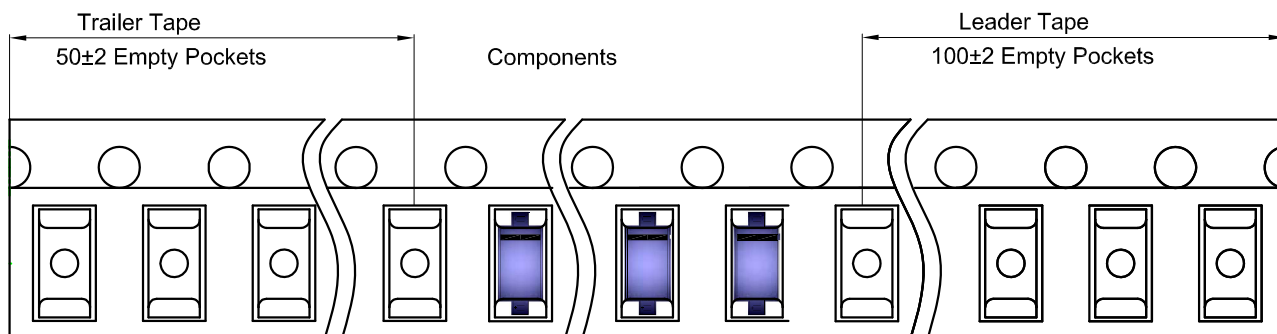

SOD-123 Reel

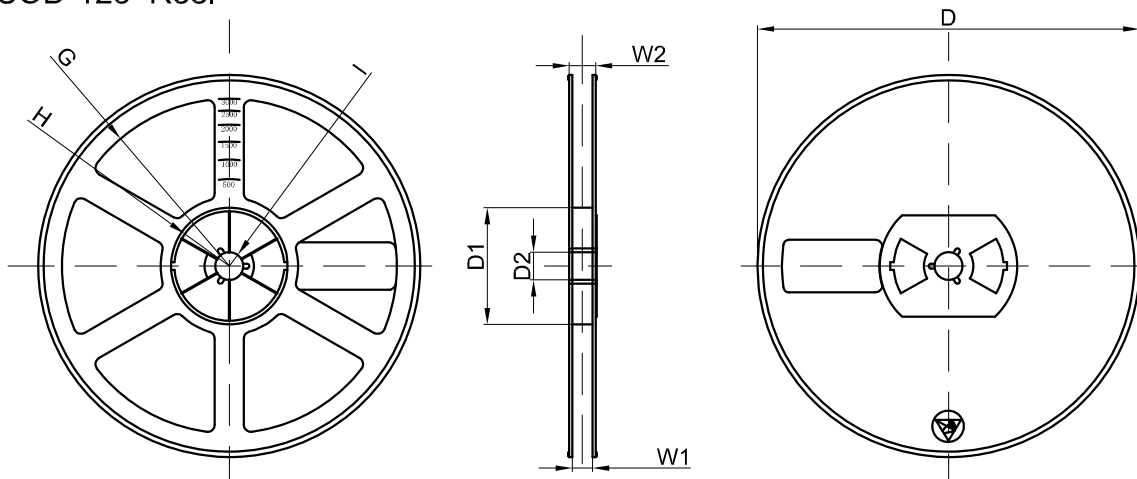

Dimensions are in millimeter

Reel Option	D	D1	D2	G	H	I	W1	W2
7" Dia	Ø178.00	54.40	13.00	R78.00	R25.60	R6.50	9.50	12.30

REEL	Reel Size	Box	Box Size(mm)	Carton	Carton Size(mm)	G.W.(kg)
3000 pcs	7 inch	45,000 pcs	203×203×195	180,000 pcs	438×438×220	