



SOT-563 Plastic-Encapsulate Transistors

BC847BVN DUAL TRANSISTOR (NPN+PNP)

FEATURES

- Epitaxial Die Construction
- Two isolated NPN/PNP(BC847W+BC857W) Transistors in one package

MAKING: KAW

MAXIMUM RATINGS TR1 (T_a=25°C unless otherwise noted)

Symbol	Parameter	Value	Units
V _{CB0}	Collector-Base Voltage	50	V
V _{CEO}	Collector-Emitter Voltage	45	V
V _{EBO}	Emitter-Base Voltage	6	V
I _c	Collector Current –Continuous	0.1	A
P _c	Collector Power Dissipation	150	mW
T _J , T _{stg}	Operation Junction and Storage Temperature Range	-55~+150	°C

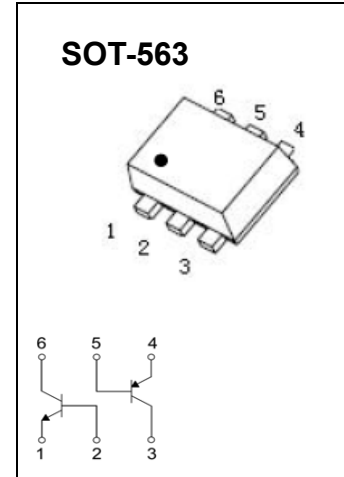

CHARACTERISTICS of TR1 (NPN Transistor) (T_a=25°C unless otherwise specified)

Parameter	Symbol	Test conditions	Min	Typ	Max	Unit
Collector-base breakdown voltage	V _{(BR)CBO}	I _C =10μA, I _E =0	50			V
Collector-emitter breakdown voltage	V _{(BR)CEO}	I _C =10mA, I _B =0	45			V
Emitter-base breakdown voltage	V _{(BR)EBO}	I _E =1μA, I _C =0	6			V
Collector cut-off current	I _{CBO}	V _{CB} =30V, I _E =0			15	nA
Emitter cut-off current	I _{EBO}	V _{EB} =5V, I _C =0			15	nA
DC current gain	h _{FE}	V _{CE} =5V, I _C =2mA	200		450	
Collector-emitter saturation voltage	V _{CE(sat)}	I _C =10mA, I _B =0.5mA			0.25	V
	V _{CE(sat)}	I _C =100mA, I _B =5mA			0.6	V
Base-emitter saturation voltage	V _{BE(sat)}	I _C =10mA, I _B =0.5mA		0.7		V
	V _{BE(sat)}	I _C =100mA, I _B =5mA		0.9		V
Base-emitter voltage	V _{BE(on)}	V _{CE} =5V, I _C =2mA	0.58		0.7	V
	V _{BE(on)}	V _{CE} =5V, I _C =10mA			0.72	V
Collector output capacitance	C _{ob}	V _{CB} =10V, I _E =0, f=1MHz			6.0	pF
Transition frequency	f _T	V _{CE} =5V, I _C =10mA, f=100MHz	100			MHz
Noise figure	NF	V _{CE} =5V, I _c =0.2mA, f=1kHz, R _g =2KΩ, Δf=200Hz			10	dB

MAXIMUM RATINGS TR2 (T_a=25°C unless otherwise noted)

Symbol	Parameter	Value	Units
V _{CB0}	Collector-Base Voltage	-50	V
V _{CE0}	Collector-Emitter Voltage	-45	V
V _{EBO}	Emitter-Base Voltage	-5	V
I _c	Collector Current –Continuous	-0.1	A
P _{C*}	Collector Power Dissipation	150	mW
T _J ,T _{stg}	Operation Junction and Storage Temperature Range	-55~+150	°C

CHARACTERISTICS of TR2 (PNP Transistor) (T_a=25°C unless otherwise specified)

Parameter	Symbol	Test conditions	MIN	TYP	MAX	UNIT
Collector-base breakdown voltage	V _{(BR)CBO}	I _C =-10μA, I _E =0	-50			V
Collector-emitter breakdown voltage	V _{(BR)CEO}	I _C =-10mA, I _B =0	-45			V
Emitter-base breakdown voltage	V _{(BR)EBO}	I _E =-1μA, I _C =0	-5			V
Collector cut-off current	I _{CBO}	V _{CB} =-30V, I _E =0			-15	nA
Emitter cut-off current	I _{EBO}	V _{EB} =-5V, I _C =0			-15	nA
DC current gain	h _{FE1}	V _{CE} =-5V, I _C =-2mA	220		475	
Collector-emitter saturation voltage	V _{CE(sat)}	I _C =-10mA, I _B =-0.5mA			-0.3	V
	V _{CE(sat)}	I _C =-100mA, I _B =-5mA			-0.65	V
Base-emitter saturation voltage	V _{BE(sat)}	I _C =-10mA, I _B =-0.5mA		-0.7		V
	V _{BE(sat)}	I _C =-100mA, I _B =-5mA			-0.95	V
Base-emitter voltage	V _{BE(on)}	V _{CE} =-5V, I _C =-2mA	-0.6		-0.75	V
	V _{BE(on)}	V _{CE} =-5V, I _C =-10mA			-0.82	V
Collector output capacitance	C _{ob}	V _{CB} =-10V, I _E =0, f=1MHz			4.5	pF
Transition frequency	f _T	V _{CE} =-5V, I _C =-10mA, f=100MHz	100			MHz
Noise figure	NF	V _{CE} =-5V, I _c =-0.2mA, f=1kHz, R _g =2KΩ, Δf=200Hz			10	dB

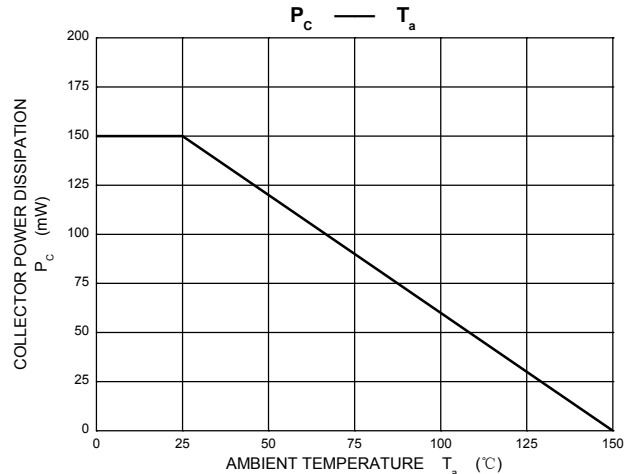
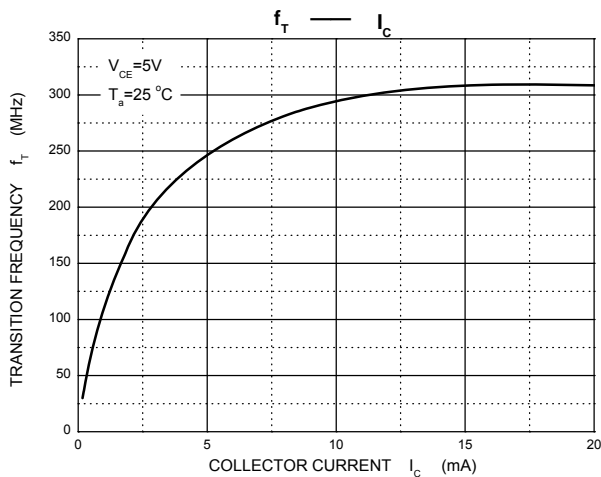
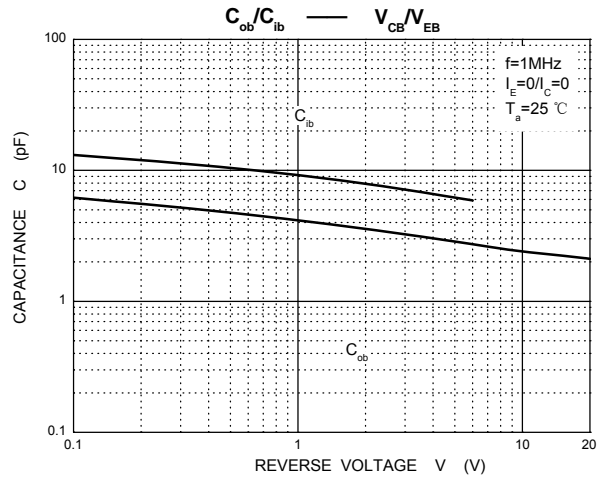
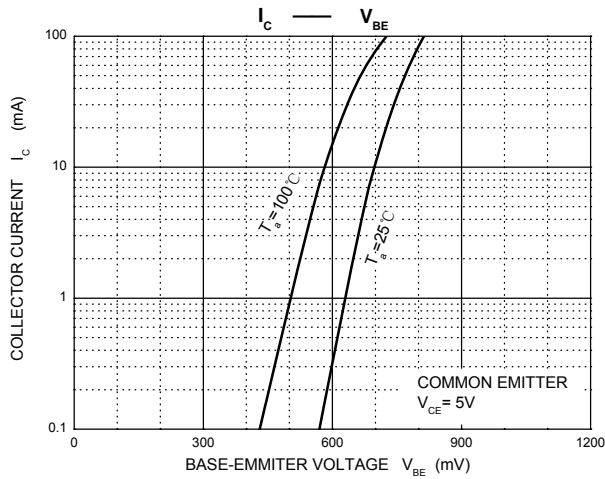
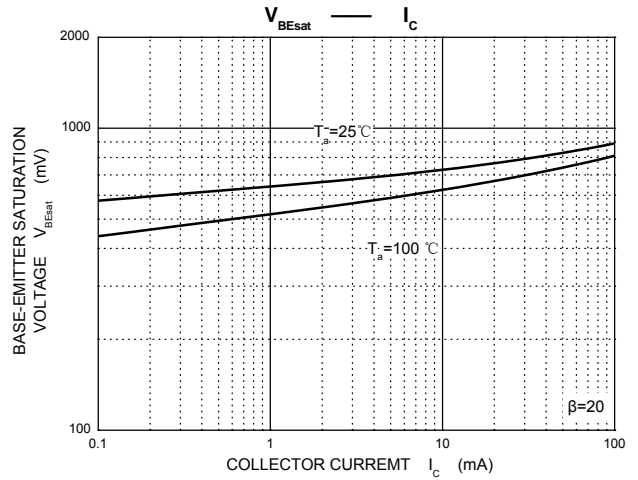
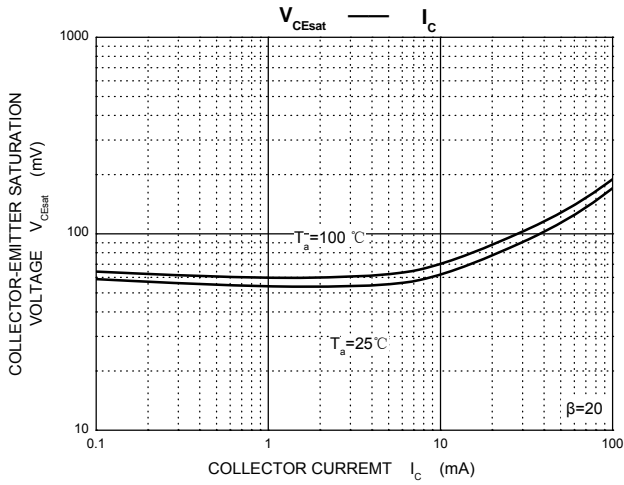
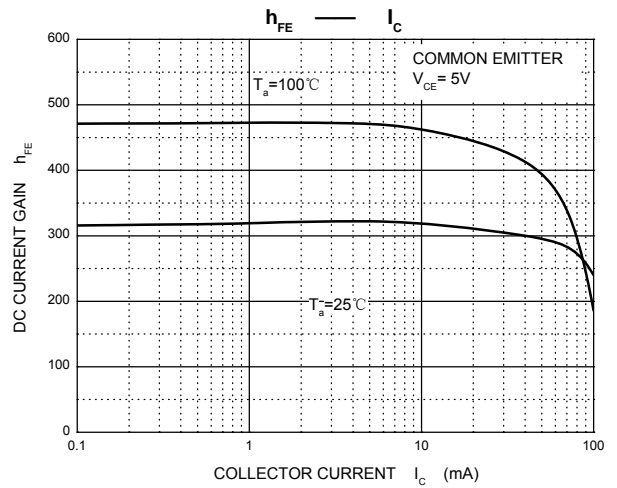
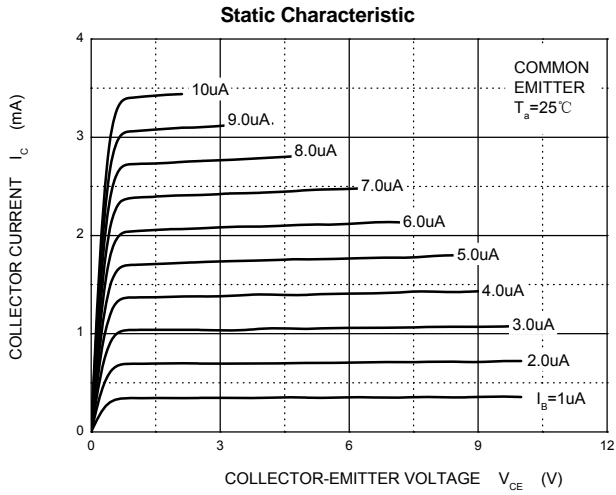

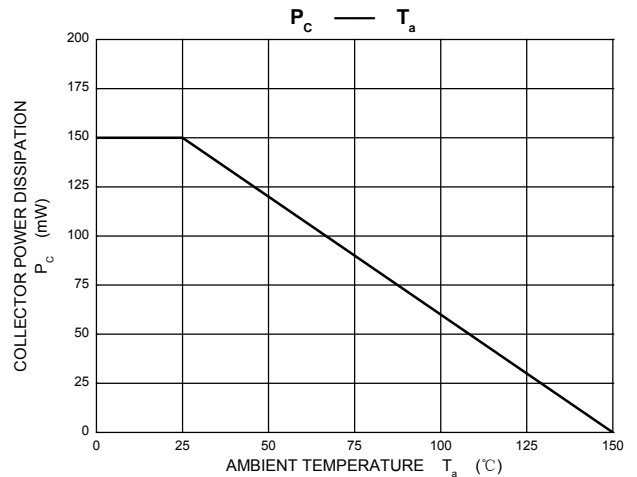
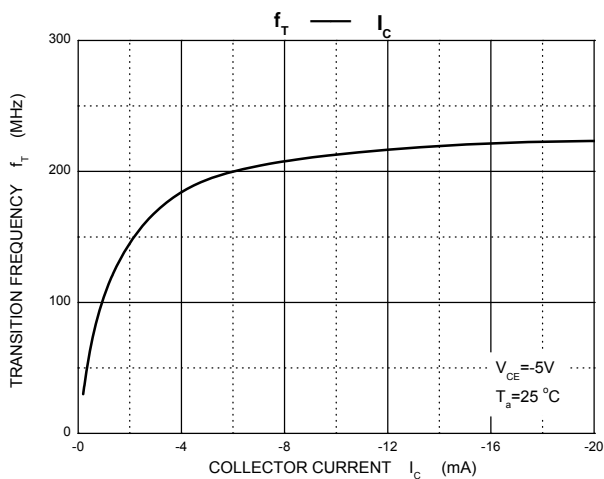
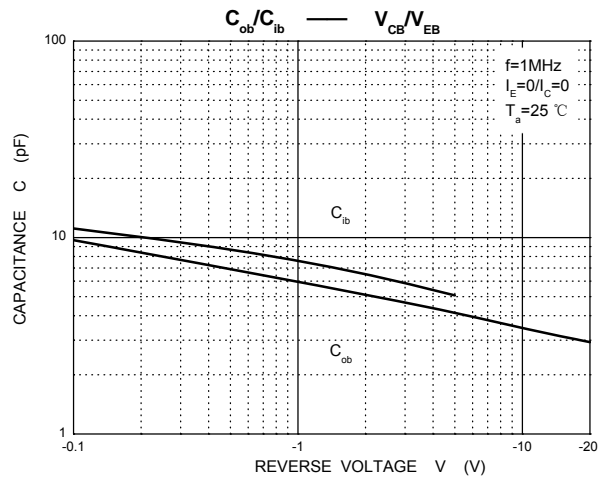
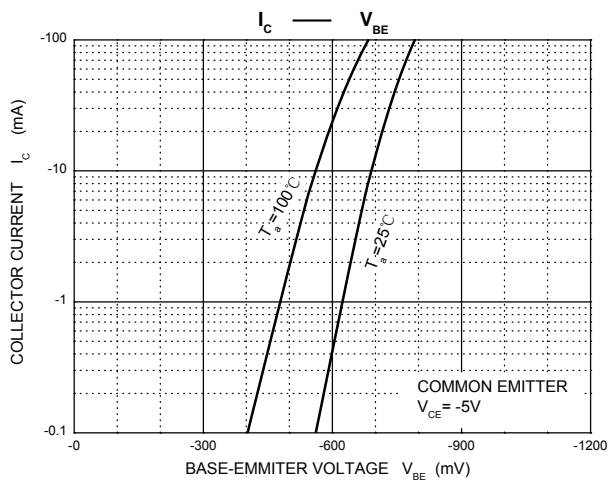
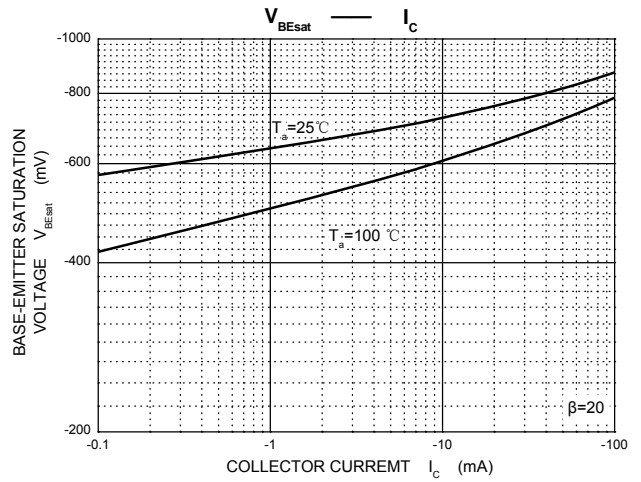
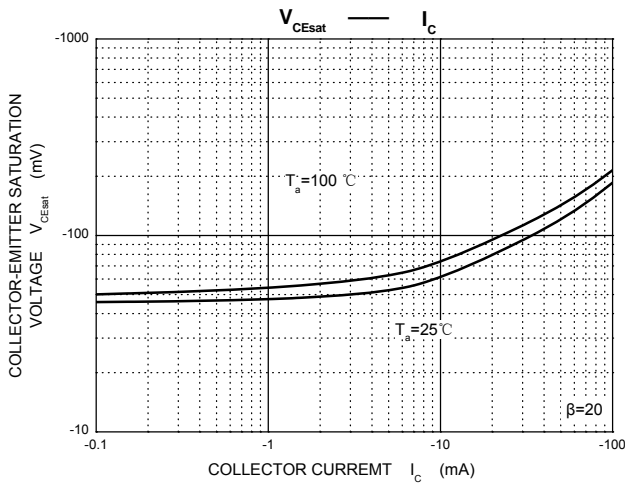
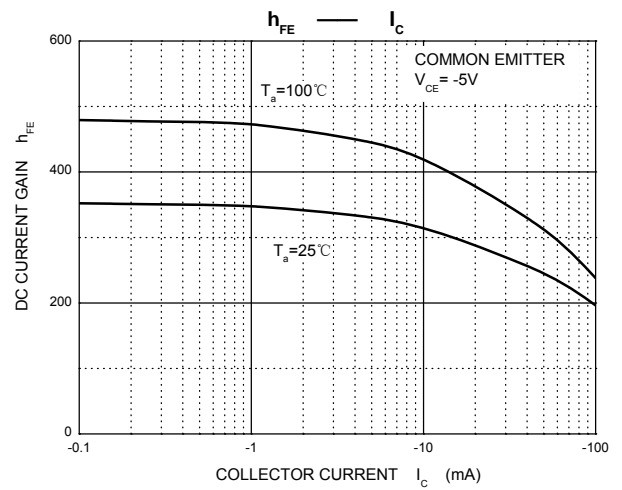
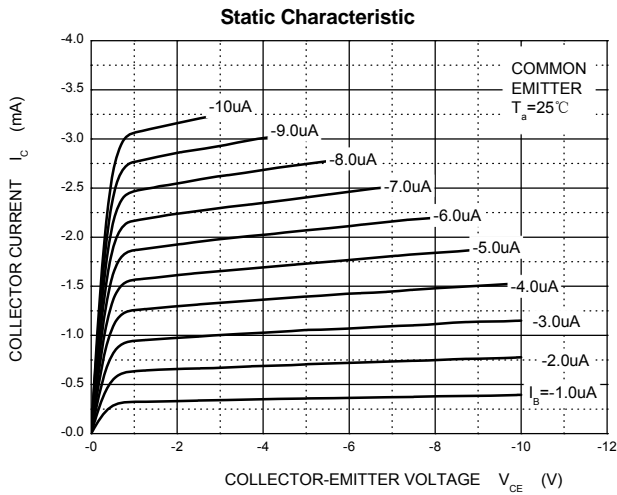

SOT-563 Package Outline Dimensions

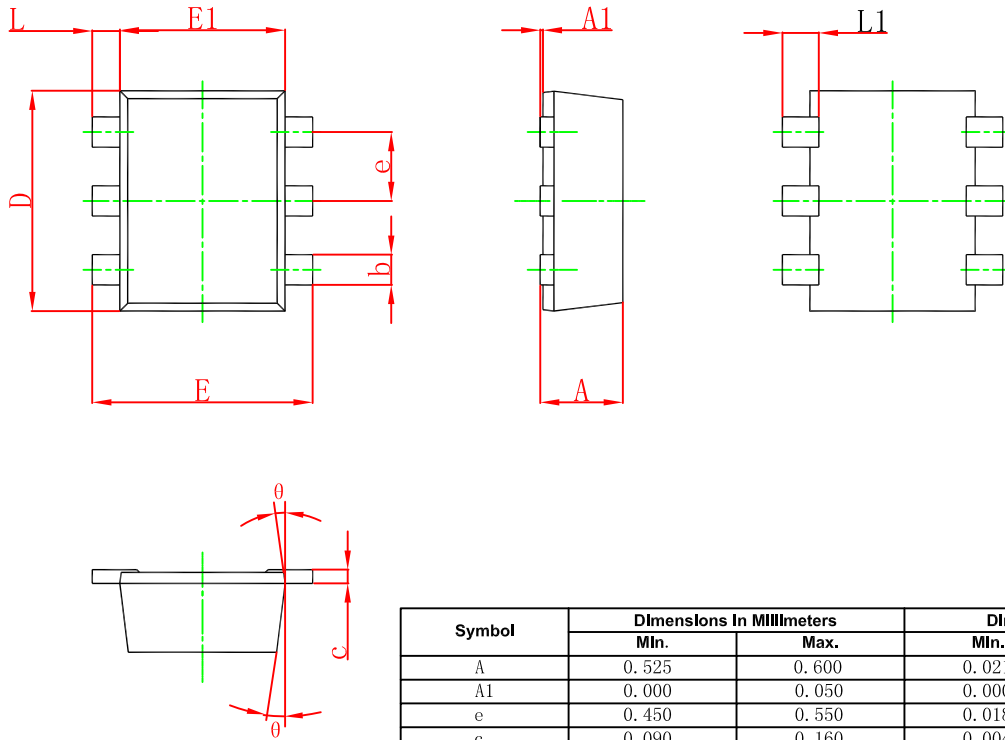

Symbol	Dimensions In Millimeters		Dimensions In Inches	
	Min.	Max.	Min.	Max.
A	0.525	0.600	0.021	0.024
A1	0.000	0.050	0.000	0.002
e	0.450	0.550	0.018	0.022
c	0.090	0.160	0.004	0.006
D	1.500	1.700	0.059	0.067
b	0.170	0.270	0.007	0.011
E1	1.100	1.300	0.043	0.051
E	1.500	1.700	0.059	0.067
L	0.100	0.300	0.004	0.012
L1	0.200	0.400	0.008	0.016
θ	10° REF.		10° REF.	

SOT-563 Suggested Pad Layout

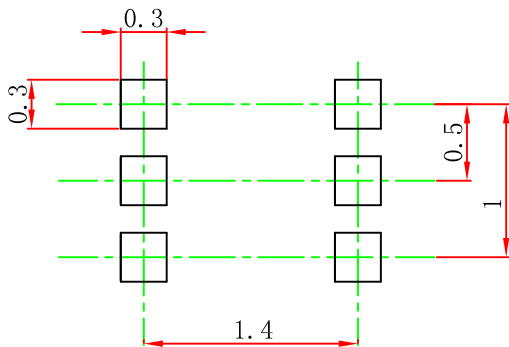

Note:

1. Controlling dimension: in millimeters.
2. General tolerance: ± 0.05 mm.
3. The pad layout is for reference purposes only.

SOT-563 Tape and Reel

SOT-563 Embossed Carrier Tape

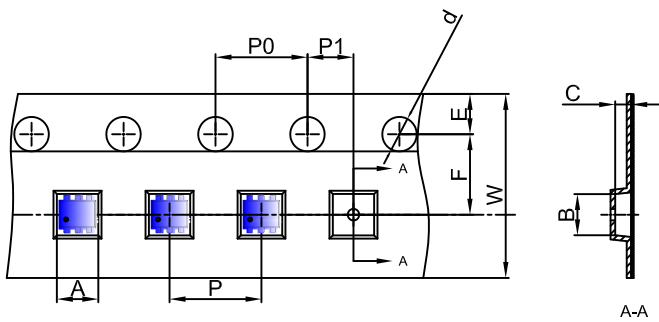

Packaging Description:

SOT-563 parts are shipped in tape. The carrier tape is made from a dissipative (carbon filled) polycarbonate resin. The cover tape is a multilayer film (Heat Activated Adhesive in nature) primarily composed of polyester film, adhesive layer, sealant, and anti-static sprayed agent. These reeled parts in standard option are shipped with 3,000 units per 7" or 17.8cm diameter reel. The reels are clear in color and is made of polystyrene plastic (anti-static coated).

Dimensions are in millimeter										
Pkg type	A	B	C	d	E	F	P0	P	P1	W
SOT-563	1.78	1.78	0.69	Ø1.50	1.75	3.50	4.00	4.00	2.00	8.00

SOT-563 Tape Leader and Trailer

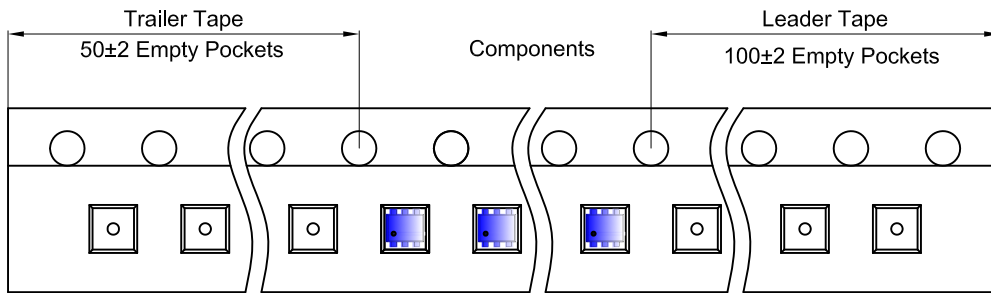

SOT-563 Reel

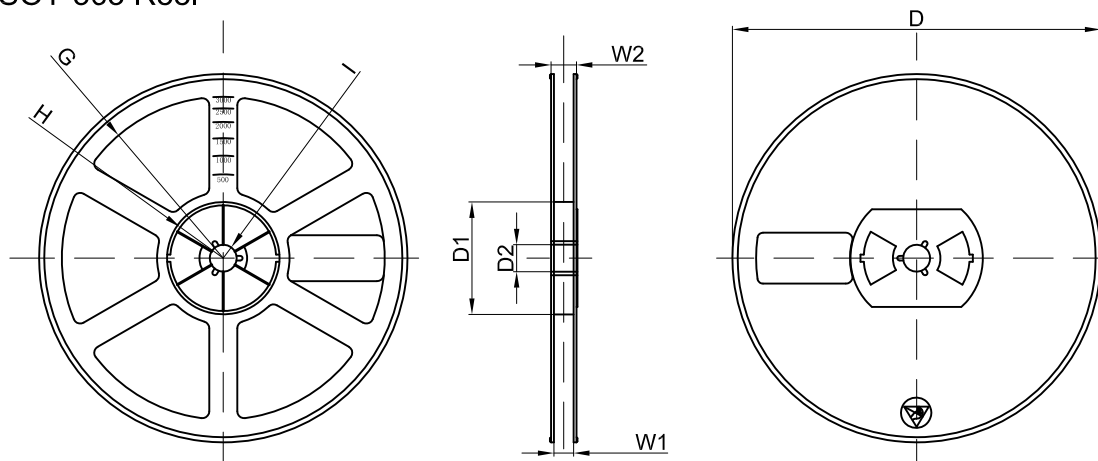

Dimensions are in millimeter								
Reel Option	D	D1	D2	G	H	I	W1	W2
7"Dia	Ø178.00	54.40	13.00	R78.00	R25.60	R6.50	9.50	12.30

REEL	Reel Size	Box	Box Size(mm)	Carton	Carton Size(mm)	G.W.(kg)
3000 pcs	7 inch	45,000 pcs	203×203×195	180,000 pcs	438×438×220	