



DONGGUAN NANJING ELECTRONICS LTD.,
TO-247-2 Silicon Carbide Schottky Diode

NJ12030U2 SiC Diode 1200V, 30A, 177nC

General Description

This product family offers state of the art performance. It is designed for high frequency applications here high efficiency and high reliability are required.

Features

- Max junction temperature 175°C
- High surge current capacity
- Zero reverse recovery current
- Zero forward recovery voltage
- High frequency operation
- Temperature independent switching behavior
- Positive temperature coefficient on V_F



**TO-247-2
Pin definition**

Applications

- Solar booster
- Inverter free wheeling diode
- Vienna 3-Phase PFC
- EV charger piles
- Switch Mode Power Supplies

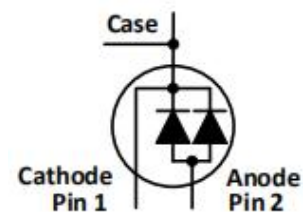

Key performance parameters

Type	V_{RRM}	I_F $T_C=141^\circ\text{C}$	Q_C
NJ12030U2	1200V	30A	177nC

Caution: This device is sensitive to electrostatic discharge .Users should follow ESD handling procedures.

Typical Characteristics

Maximum Ratings

$T_C=25^{\circ}\text{C}$, unless otherwise specified

Parameter	Symbol	Value	Unit
Repetitive Peak Reverse Voltage	V_{RRM}	1200	V
DC Peak Reverse Voltage	V_{DC}	1200	V

Maximum Ratings

$T_C=25^{\circ}\text{C}$, unless otherwise specified

Parameter	Symbol	Value	Unit
Continuous Forward Current: $T_C = 25^{\circ}\text{C}$ $T_C = 141^{\circ}\text{C}$	I_F	69 30	A
Non-Repetitive Forward Surge Current: Sine half wave $T_C = 25^{\circ}\text{C}$ $t_p = 10\text{ms}$	I_{FSM}	224	A
Power Dissipation: $T_C = 25^{\circ}\text{C}$ $T_C = 150^{\circ}\text{C}$	P_{tot}	288 48	W
i^2t value : $T_C = 25^{\circ}\text{C}$ $t_p = 10\text{ms}$	$\int i^2 dt$	250	A^2S
Operating Junction temperature Range	T_j	-55 to +175	$^{\circ}\text{C}$
Storage temperature Range	T_{stg}	-55 to +175	$^{\circ}\text{C}$

Typical Characteristics

Thermal Resistance

Parameter	Symbol	Typ.	Unit
Thermal resistance of crust	R_{thJC}	0.52	$^{\circ}\text{C}/\text{W}$

Electrical Characteristics

$T_C = 25^{\circ}\text{C}$, unless otherwise specified

Parameter	Symbol	Value			Unit	Test Condition
		Min.	Typ.	Max.		
Forward Voltage	V_F		1.56 2.25	1.8 3.0	V	$I_F = 30\text{A}$ $T_j = 25^{\circ}\text{C}$ $T_j = 175^{\circ}\text{C}$
Reverse Current	I_R		15 65	160 600	μA	$V_R = 1200\text{V}$ $T_j = 25^{\circ}\text{C}$ $T_j = 175^{\circ}\text{C}$
Total Capacitive Charge	Q_C		177		nC	$V_R = 800\text{V}$ $T_j = 25^{\circ}\text{C}$ $Q_C = \int_0^{V_R} C(V)dV$
Total Capacitance	C		1790 168 117		pF	$T_j = 25^{\circ}\text{C}$, $f = 1\text{MHz}$ $V_R = 1\text{V}$ $V_R = 400\text{V}$ $V_R = 800\text{V}$

Characteristics Curves

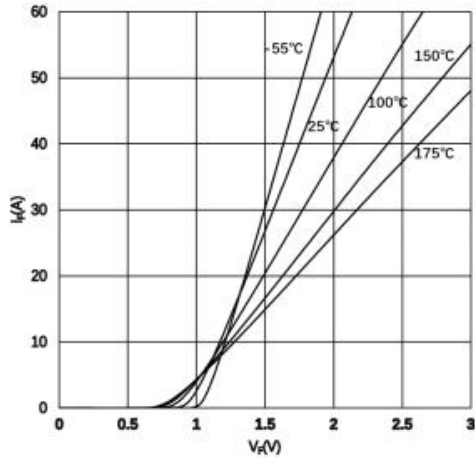

Fig. 1 Typical forward characteristic curve

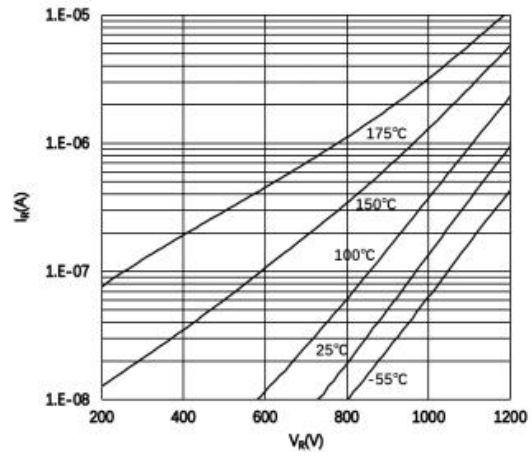

Fig. 2 Typical reverse characteristic curve

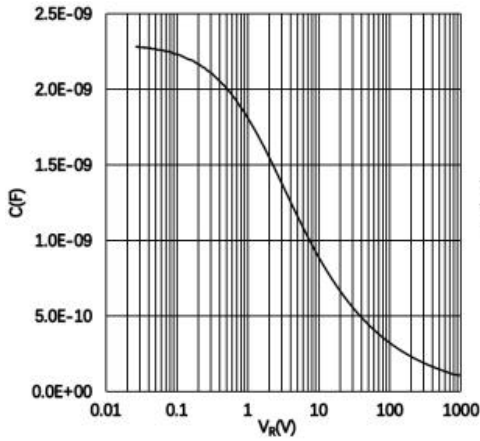

Fig. 3 Typical capacitance and reverse voltage curve

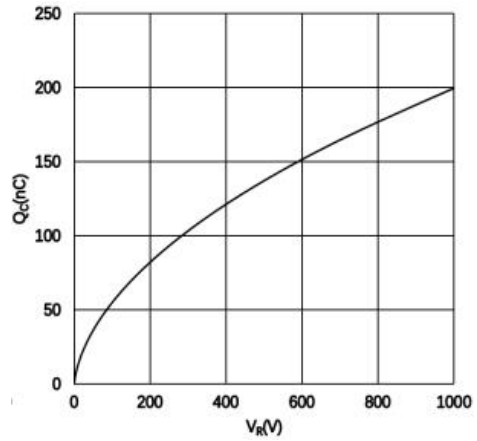

Fig. 4 Typical storage charge and reverse voltage curve

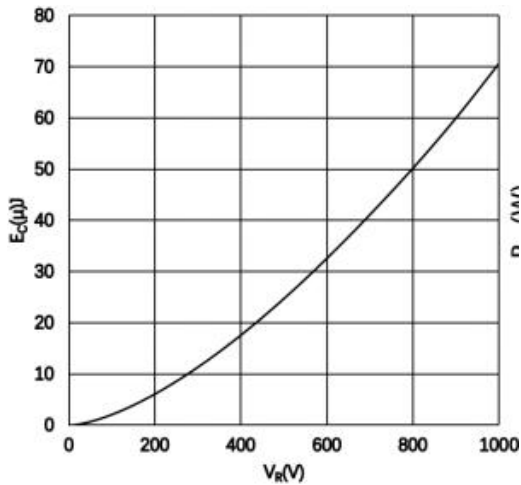

Fig. 5 Typical capacitance energy and reverse voltage curve

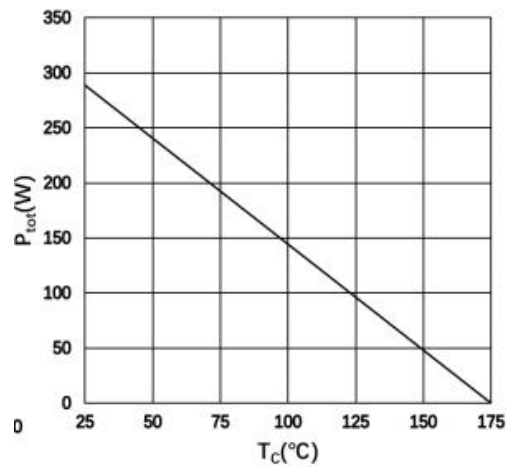

Fig. 6 Typical power derating curve

Typical Characteristics

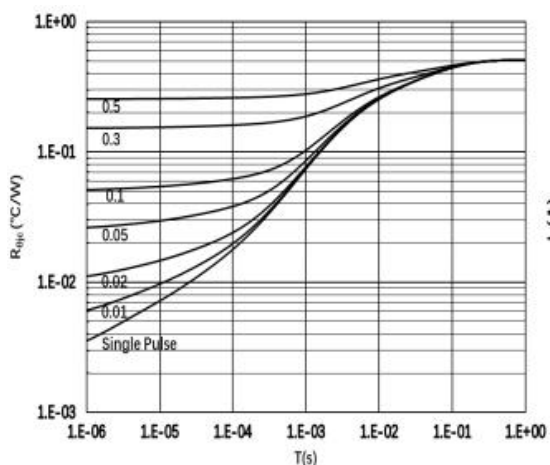

Fig. 7 Transient thermal impedance

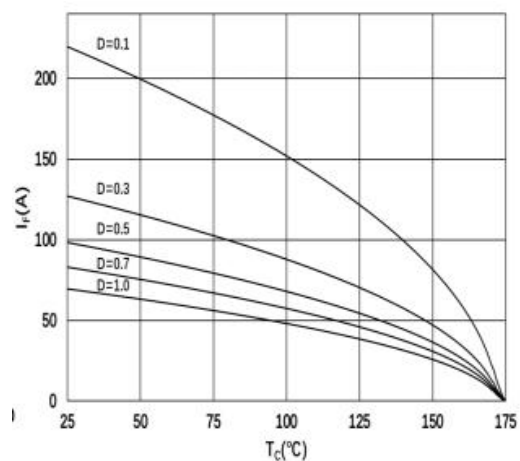
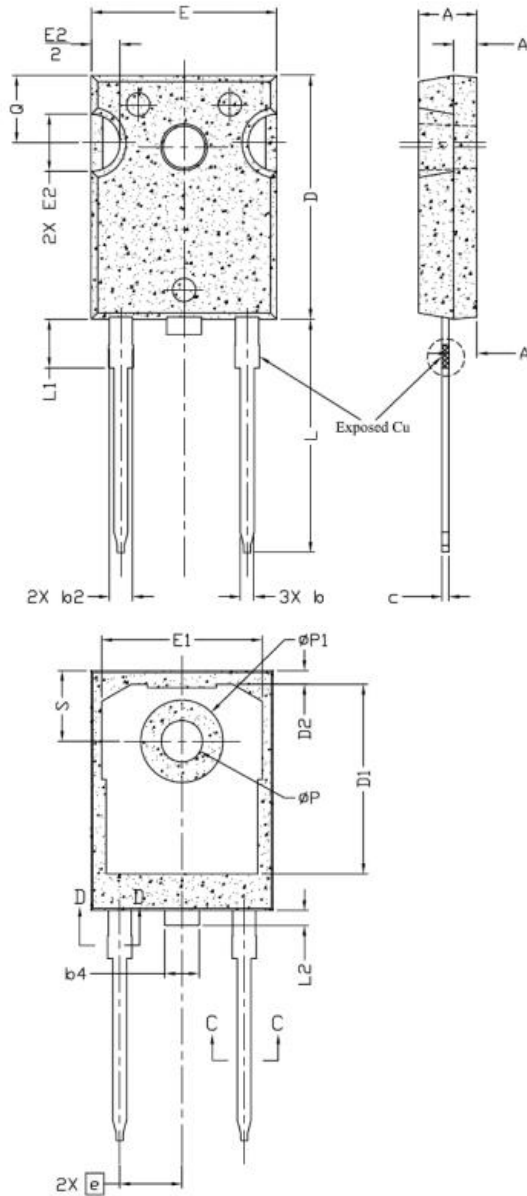

Fig. 8 Current curve under different loads

Package Outline:TO-247-2



SYMBOL	DIMENSIONS			NOTES
	MIN.	NOM.	MAX.	
A	4.83	5.02	5.21	
A1	2.29	2.41	2.55	
A2	1.50	2.00	2.49	
b	1.12	1.20	1.33	
b1	1.12	1.20	1.28	
b2	1.91	2.00	2.39	6
b3	1.91	2.00	2.34	
b4	2.87	3.00	3.22	6, 8
b5	2.87	3.00	3.18	
c	0.55	0.60	0.69	6
c1	0.55	0.60	0.65	
D	20.80	20.95	21.10	4
D1	16.25	16.55	17.65	5
D2	0.51	1.19	1.35	
E	15.75	15.94	16.13	4
E1	13.46	14.02	14.16	5
E2	4.32	4.91	5.49	3
e	5.44BSC			
L	19.81	20.07	20.32	
L1	4.10	4.19	4.40	6
L2	1.00	1.30	1.50	
∅P	3.56	3.61	3.65	7
∅P1	6.90	7.09	7.15	
Q	5.39	5.79	6.20	
S	6.04	6.17	6.30	

Dimensions in (mm)

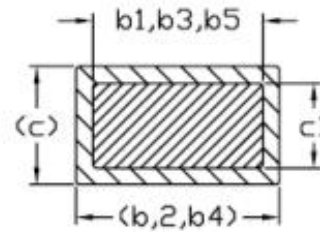

Section C—C, D—D