



***SF900R12D7* Half Bridge IGBT Module**

电气特性 / Features and Benefits:

- 1200V 沟槽栅/场终止工艺
1200V trench gate/field termination process
- 低开关损耗
Low switching losses
- 正温度系数
Vcesat with positive temperature coefficient

典型应用 / Application:

- UPS 系统
UPS system
- 伺服驱动器
Servo drives
- 大功率变流器
High Power Converters
- 电机传动
Motor drives

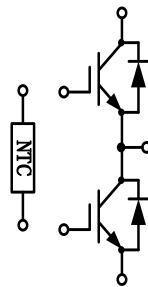

$V_{CES} = 1200V$, $I_{C\ nom} = 900A$ / $I_{CRM} = 1800A$

IGBT, 逆变器 / IGBT, Inverter

最大额定值 / Maximum Ratings

Parameter	Conditions	Symbol	Value	Unit
集电极-发射极电压 Collector-Emitter voltage	$T_{vj} = 25^{\circ}C$	V_{CES}	1200	V
连续集电极直流电流 Continuous DC collector current	$T_C = 100^{\circ}C$, $T_{vj\ max} = 175^{\circ}C$	$I_{C\ nom}$	900	A
模块端子的最大均方根电流 Maximum RMS module DC-terminal current	$T_{Terminal} \leq 90^{\circ}C$, $T_c = 90^{\circ}C$ $T_{Terminal} \leq 105^{\circ}C$, $T_c = 90^{\circ}C$	I_{TRMS}	580 565	A
集电极重复峰值电流 Repetitive peak collector current	$t_p = 1ms$	I_{CRM}	1800	A

Typical Characteristics

总功率损耗 Total power dissipation	$T_C = 25^\circ\text{C}, T_{vj\text{max}} = 175^\circ\text{C}$	P_{tot}	2600	W
栅极-发射极电压 Gate emitter voltage		V_{GE}	± 20	V

特征值 / Characteristic Values

Parameter	Conditions	Symbol	Value			Unit
			Min.	Typ.	Max.	
集电极-发射极饱和电压 Collector-Emitter saturation voltage	$V_{\text{GE}}=15\text{V}, I_{\text{C}}=900\text{A}$ $V_{\text{GE}}=15\text{V}, I_{\text{C}}=900\text{A}$ $V_{\text{GE}}=15\text{V}, I_{\text{C}}=900\text{A}$	$T_{vj}=25^\circ\text{C}$ $T_{vj}=125^\circ\text{C}$ $T_{vj}=175^\circ\text{C}$	$V_{\text{CE sat}}$	1.75 2.15 2.30	2.20	V
栅极-发射极阈值电压 Gate-Emitter threshold voltage	$I_{\text{C}}=18\text{mA}, V_{\text{GE}}=V_{\text{CE}},$	$T_{vj}=25^\circ\text{C}$	V_{GEth}	5.2	5.8	6.4
栅电荷 Gate charge	$V_{\text{GE}}=-15\text{V}..+15\text{V}$		Q_{G}	11		μC
内部栅极电阻 Internal gate resistor	$T_{vj}=25^\circ\text{C}$		R_{Gint}	0.6		Ω
输入电容 Input capacitance	$f=100\text{KHz}, V_{\text{CE}}=25\text{V}, V_{\text{GE}}=0\text{V}$	$T_{vj}=25^\circ\text{C}$	C_{ies}	139		nF
反向传输电容 Reverse transfer capacitance			C_{res}	0.55		
集电极-发射极截止电流 Collector-emitter cut-off current	$V_{\text{CE}}=1200\text{V}, V_{\text{GE}}=0\text{V}$	$T_{vj}=25^\circ\text{C}$	I_{CES}		0.1	mA
栅极-发射极漏电流 Gate-emitter leakage current	$V_{\text{CE}}=0\text{V}, V_{\text{GE}}=20\text{V}$	$T_{vj}=25^\circ\text{C}$	I_{GES}		100	nA
开通延迟时间 Turn-on delay time	$I_{\text{C}}=900\text{A}, V_{\text{CE}}=600\text{V}$ $V_{\text{GE}}=\pm 15\text{V}, R_{\text{G}}=0.5\Omega$ (电感负载) / (inductive load)	$T_{vj}=25^\circ\text{C}$ $T_{vj}=125^\circ\text{C}$ $T_{vj}=175^\circ\text{C}$	t_{don}	446 468 490		
上升时间 Rise time	$I_{\text{C}}=900\text{A}, V_{\text{CE}}=600\text{V}$ $V_{\text{GE}}=\pm 15\text{V}, R_{\text{G}}=0.5\Omega$ (电感负载) / (inductive load)	$T_{vj}=25^\circ\text{C}$ $T_{vj}=125^\circ\text{C}$ $T_{vj}=175^\circ\text{C}$	t_{r}	110 132 138		
关断延迟时间 Turn-off delay time	$I_{\text{C}}=900\text{A}, V_{\text{CE}}=600\text{V}$ $V_{\text{GE}}=\pm 15\text{V}, R_{\text{G}}=0.5\Omega$ (电感负载) / (inductive load)	$T_{vj}=25^\circ\text{C}$ $T_{vj}=125^\circ\text{C}$ $T_{vj}=175^\circ\text{C}$	t_{doff}	436 494 523		ns
下降时间 Fall time	$I_{\text{C}}=900\text{A}, V_{\text{CE}}=600\text{V}$ $V_{\text{GE}}=\pm 15\text{V}, R_{\text{G}}=0.5\Omega$ (电感负载) / (inductive load)	$T_{vj}=25^\circ\text{C}$ $T_{vj}=125^\circ\text{C}$ $T_{vj}=175^\circ\text{C}$	t_{f}	132 222 281		
开通损耗能量 (每脉冲) Turn-on energy loss per pulse	$I_{\text{C}}=900\text{A}, V_{\text{CE}}=600\text{V}$ $di/dt=5200\text{A/us}(T_{vj}=175^\circ\text{C})$ $V_{\text{GE}}=\pm 15\text{V}, R_{\text{G}}=0.5\Omega$	$T_{vj}=25^\circ\text{C}$ $T_{vj}=125^\circ\text{C}$ $T_{vj}=175^\circ\text{C}$	E_{on}	142 210 246		mJ
关断损耗能量 (每脉冲) Turn-off energy loss per pulse	$I_{\text{C}}=900\text{A}, V_{\text{CE}}=600\text{V}$ $dv/dt=3900\text{V/us}(T_{vj}=175^\circ\text{C})$ $V_{\text{GE}}=\pm 15\text{V}, R_{\text{G}}=0.5\Omega$	$T_{vj}=25^\circ\text{C}$ $T_{vj}=125^\circ\text{C}$ $T_{vj}=175^\circ\text{C}$	E_{off}	78 105 119		mJ

Typical Characteristics

短路数据 SC data	$V_{GE} \leq 15V, V_{CC} = 800V \quad t_p \leq 8\mu s, T_{vj} = 150^\circ C$ $V_{CEmax} = V_{CES} - L_{sCE} \cdot di/dt \quad t_p \leq 6\mu s, T_{vj} = 175^\circ C$	I_{sc}		3000 2900		A
结-外壳热阻 Thermal resistance, junction to case	每个 IGBT / per IGBT	R_{thJC}			0.057	K/W
在开关状态下温度 Temperature under switching conditions	$T_{vj\ op} > 150^\circ C$ is only allowed for operation at overload conditions.	$T_{vj\ op}$	-40		175	$^\circ C$

二极管, 逆变器 / Diode, Inverter

最大额定值 / Maximum Ratings

Parameter	Conditions	Symbol	Value	Unit
反向重复峰值电压 Repetitive peak reverse voltage	$T_{vj} = 25^\circ C$	V_{RRM}	1200	V
连续正向直流电流 Continuous DC forward current		I_F	900	A
正向重复峰值电流 Repetitive peak forward current	$t_p = 1ms$	I_{FRM}	1800	A
I^2t 值 I^2t -value	$t_p = 10ms, \sin 180^\circ, T_j = 125^\circ C$	I^2t	45000	A^2s

特征值 / Characteristic Values

Parameter	Conditions	Symbol	Value			Unit
			Min.	Typ.	Max.	
正向电压 Forward voltage	$I_F = 900A, V_{GE} = 0V$ $I_F = 900A, V_{GE} = 0V$	$T_{vj} = 25^\circ C$ $T_{vj} = 125^\circ C$ $T_{vj} = 175^\circ C$	V_F		1.6 1.65 1.65	2.0 V
反向恢复峰值电流 Peak reverse recovery current	$I_F = 900A$ $-di_F/dt = 5200A/\mu s (T_{vj} = 175^\circ C)$ $V_R = 600V, V_{GE} = -15V$	$T_{vj} = 25^\circ C$ $T_{vj} = 125^\circ C$ $T_{vj} = 175^\circ C$	I_{RM}		352 400 416	A
恢复电荷 Recovered charge	$I_F = 900A$ $-di_F/dt = 5200A/\mu s (T_{vj} = 175^\circ C)$ $V_R = 600V, V_{GE} = -15V$	$T_{vj} = 25^\circ C$ $T_{vj} = 125^\circ C$ $T_{vj} = 175^\circ C$	Q_r		120 219 282	μC
反向恢复损耗 (每脉冲) Reverse recovered energy	$I_F = 900A$ $-di_F/dt = 5200A/\mu s (T_{vj} = 175^\circ C)$ $V_R = 600V, V_{GE} = -15V$	$T_{vj} = 25^\circ C$ $T_{vj} = 125^\circ C$ $T_{vj} = 175^\circ C$	E_{rec}		38 73 97	mJ
结-外壳热阻 Thermal resistance, junction to case	每个 Diode / per diode	R_{thJC}			0.096	K/W
在开关状态下温度 Temperature under switching conditions	$T_{vj\ op} > 150^\circ C$ is only for operation at overload conditions.	$T_{vj\ op}$	-40		175	$^\circ C$

Typical Characteristics

负温度系数热敏电阻 / NTC-Thermistor

特征值 / Characteristic Values

Parameter	Conditions	Symbol	Value			Unit
			Min.	Typ.	Max.	
额定电阻值 Rated resistances	$T_c=25^{\circ}\text{C}$, $\pm 3\%$	R_{25}		5.0		$\text{K } \Omega$
B-值 B-value	$R_2 = R_{25} \exp [B_{25/50}(1/T_2 - 1/(298,15 \text{ K}))]$	$B_{25/50}$		3375		K
B-值 B-value	$R_2 = R_{25} \exp [B_{25/80}(1/T_2 - 1/(298,15 \text{ K}))]$	$B_{25/80}$		3425		K
B-值 B-value	$R_2 = R_{25} \exp [B_{25/100}(1/T_2 - 1/(298,15 \text{ K}))]$	$B_{25/100}$		3443		K

模块 / Module

Parameter	Conditions	Symbol	Value			Unit
绝缘测试电压 Isolation test voltage	RMS, $f=50\text{Hz}$, $t=1\text{min}$	V_{ISOL}		3400		V
内部绝缘 Internal isolation	基本绝缘 (class 1, IEC 61140) basic insulation (class 1, IEC 61140)			Al_2O_3		
相对电痕指数 Comperative tracking index		CTI		>200		
相对温度指数(电) RTI Elec.	住房 housing	RTI		140		$^{\circ}\text{C}$
杂散电感, 模块 Stray inductance module		L_{sCE}		23		nH
储存温度 Storage temperature		T_{stg}	-40		125	$^{\circ}\text{C}$
模块安装的扭矩 Mounting torque for module mounting		M	3.0		6.0	Nm
端子连接扭矩 Terminal Connection Torque		M	3.0		6.0	Nm
重量 Weight		W		356		g

Typical Characteristics



图 1. 典型输出特性 ($V_{GE}=15V$)

Figure 1. Typical output characteristics ($V_{GE}=15V$)

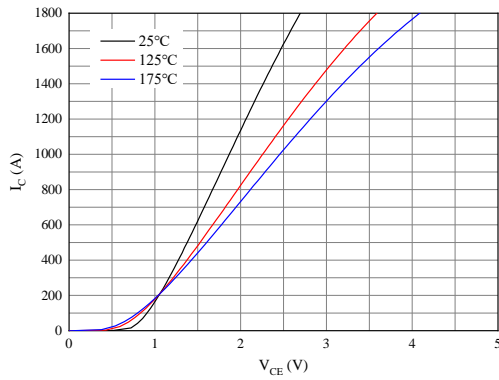

图 2. 典型输出特性 ($T_{vj}=175^{\circ}C$)

Figure 2. Typical output characteristics ($T_{vj}=175^{\circ}C$)

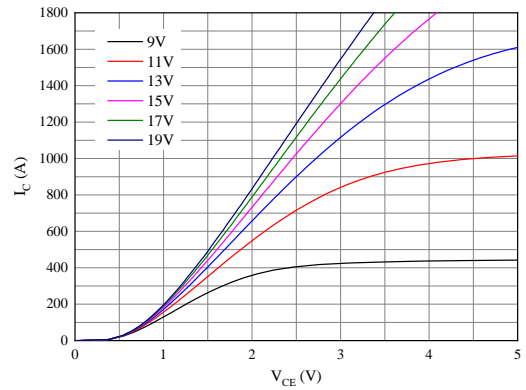

图 3. 典型传输特性 ($V_{CE}=20V$)

Figure 3. Typical transfer characteristic ($V_{CE}=20V$)

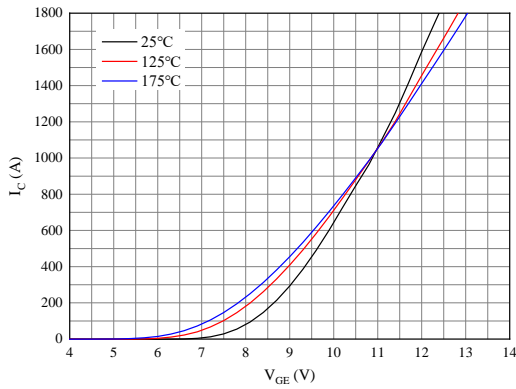

图 4. 正向偏压特性 二极管

Figure 4. Forward characteristic of Diode

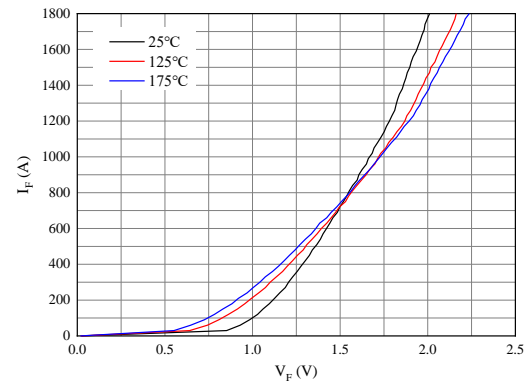

图 5. 开关损耗 逆变器

Figure 5. Switching losses of IGBT

$V_{GE}=\pm 15V$, $R_{Gon}=0.5\Omega$, $R_{Goff}=0.5\Omega$, $V_{CE}=600V$

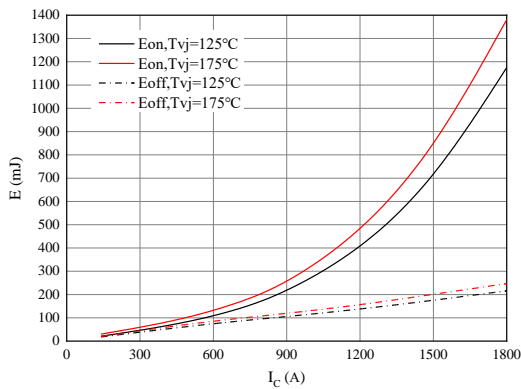

图 6. 开关损耗 逆变器

Figure 6. Switching losses of IGBT

$V_{GE}=\pm 15V$, $I_C=900A$, $V_{CE}=600V$

Typical Characteristics

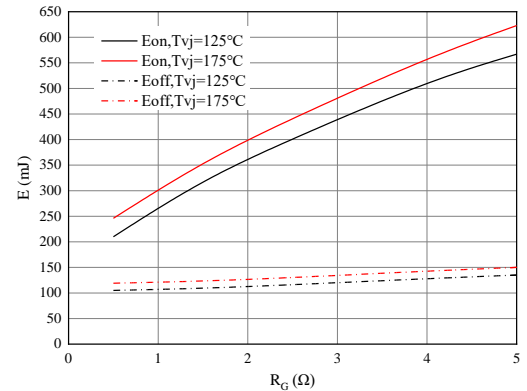

图 7. 瞬态热阻抗 IGBT 逆变器

Figure 7. Transient thermal impedance IGBT, Inverter

$$Z_{thJC}=f(t)$$

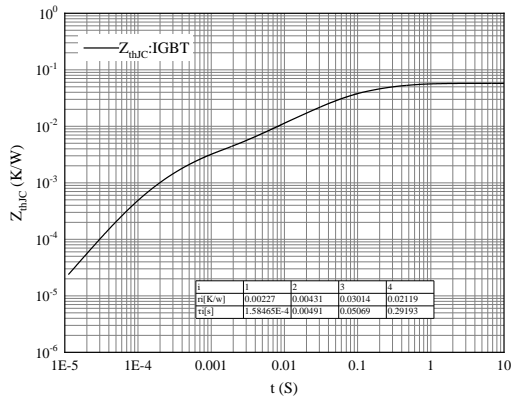

图 8. 瞬态热阻抗 FRD 逆变器

Figure 8. Transient thermal impedance FRD, Inverter

$$Z_{thJC}=f(t)$$

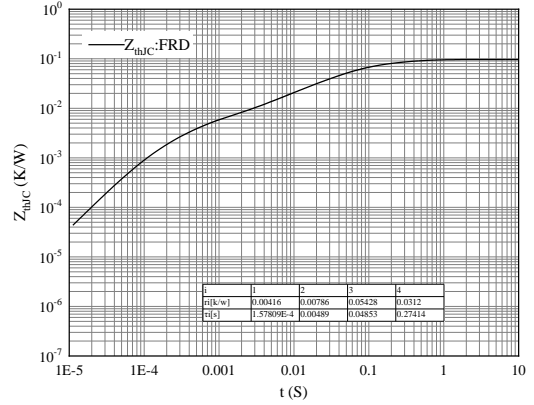

图 9. 开关损耗 二极管

Figure 9. Switching losses of Diode

$R_{Gon}=0.5\Omega, V_{CE}=600V$

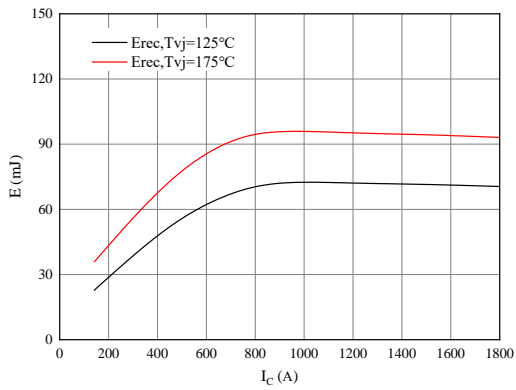

图 10. 开关损耗 二极管

Figure 10. Switching losses of Diode

$I_F=900A, V_{CE}=600V$

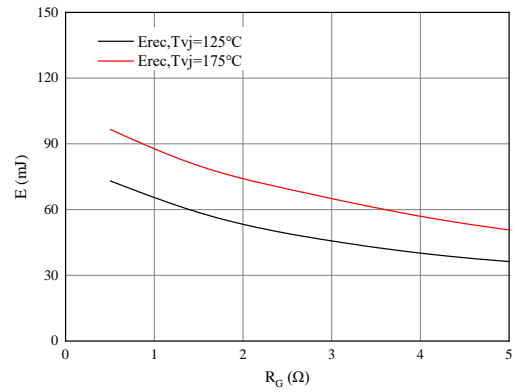

图 11. 电容特性

Figure 11. Capacitance characteristic

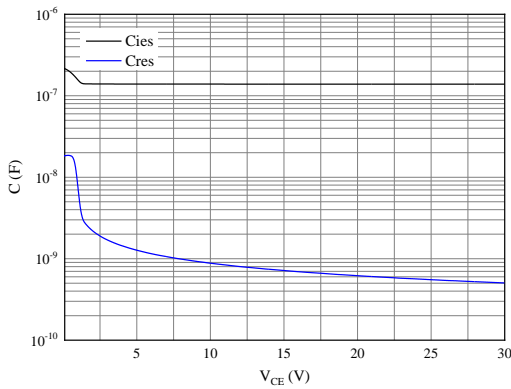

图 12. 负温系数热敏电阻 温度特性

Figure 12. NTC-Thermistor-temperature characteristic

接线图 / Circuit diagram

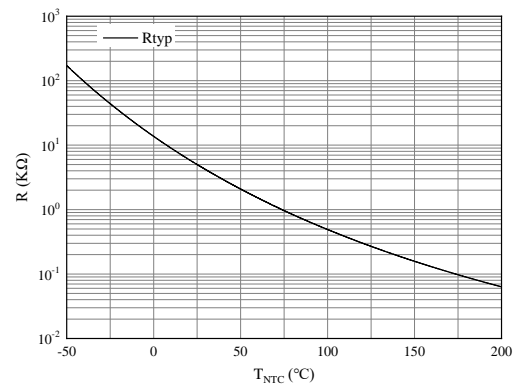
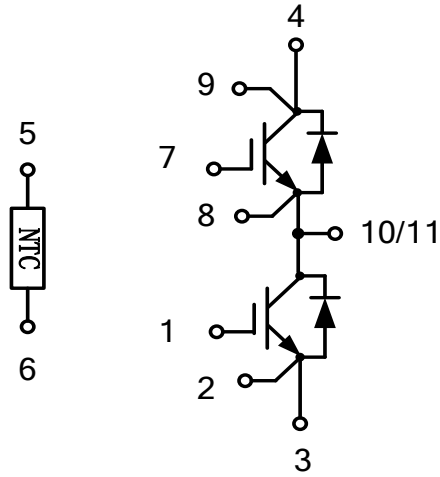

封装尺寸 / Package outlines

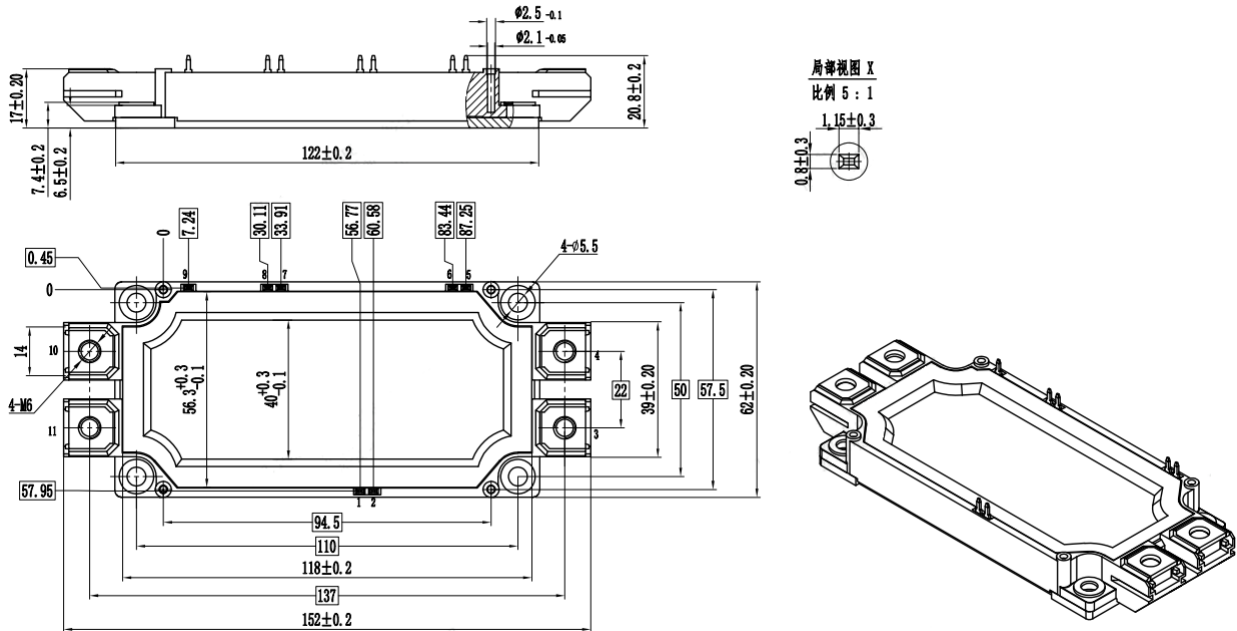

Dimensions in (mm)