



DONGGUAN NANJING ELECTRONICS LTD.,
TO-247-4 Plastic-Encapsulate IGBT

NJ75R07AC6U IGBT Discrete with Anti-Parallel Diode

电气特性/ Features and Benefits:

- 650V 沟槽栅/场终止工艺
650V trench gate/field termination process
- 低开关损耗
Low switching losses
- Vcesat 正温度系数
Vcesat has a positive temperature coefficient

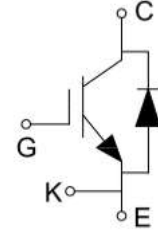

典型应用/ Applications:

- 储能逆变器
Energy storage inverter
- 不间断电源
Uninterruptible power supplies
- 光伏逆变器
Solar converters



$V_{CES} = 650V$, $I_{C\ nom} = 75A$ / $I_{CRM} = 300A$

关键性能和程序参数 / Key Performance and Package Parameters

Type	V_{CE}	I_C	$V_{CESat}, T_{vj}=25^\circ C$	T_{vjmax}	Package
NJ75R07AC6U	650V	75A	1.40V	175°C	TO-247-4L

双极晶体管/IGBT

最大额定值 / Maximum Ratings

Parameter	Conditions	Symbol	Value	Unit
集电极-发射极电压 Collector-Emitter voltage	$T_{vj}=25^\circ C$	V_{CES}	650	V
连续集电极直流电流 Continuous DC collector current	$T_C=100^\circ C, T_{vj\ max}=175^\circ C$	$I_{C\ nom}$	75	A
集电极重复峰值电流 Repetitive peak collector current	$t_p=1\ ms$	I_{CRM}	300	A
栅极-发射极电压 Gate emitter voltage	$t_p \leq 10\ \mu s, D < 0.010$	V_{GE}	± 20 +30	V
总功率损耗 Power dissipation	$T_C=25^\circ C$ $T_C=100^\circ C$	P_{tot}	520 260	W
在开关状态下温度 Temperature under switching		$T_{vj\ op}$	-40...+175	°C

Typical Characteristics

conditions				
储存温度 Storage temperature		T_{stg}	-40...+150	°C
焊接温度 Soldering temperature			260	°C
安装扭矩 Mounting torque		M	0.6	Nm

热特性 / Thermal Characteristics

Parameter	Conditions	Symbol	Value	Unit
IGBT 热阻, 结-壳 IGBT thermal resistance, junction - case		$R_{th(j-C)}$	0.29	K/W
二极管热阻, 结-壳 Diode thermal resistance, junction - case		$R_{th(j-C)}$	0.35	K/W

特征值 / Characteristic Values

Parameter	Conditions	Symbol	Value			Unit
			Min.	Typ.	Max.	
集电极-发射极饱和电压 Collector-Emitter saturation voltage	$V_{GE}=15V, I_C=75A$ $V_{GE}=15V, I_C=75A$ $V_{GE}=15V, I_C=75A$	$T_{vj}=25^{\circ}C$ $T_{vj}=150^{\circ}C$ $T_{vj}=175^{\circ}C$	V_{CEsat}	1.40 1.68 1.73	1.90	V
栅极-发射极阈值电压 Gate-Emitter threshold voltage	$I_C=0.75mA, V_{GE}=V_{CE}$	$T_{vj}=25^{\circ}C$	$V_{GE(th)}$	3.6 4.2	4.8	V
跨导 Transconductance	$V_{CE}=20V, I_C=75A$		G_{fs}	68		S
输入电容 Input capacitance			C_{ies}	4250		pF
输出电容 Output capacitance	$f=100kHz, V_{CE}=25V, V_{GE}=0V$	$T_{vj}=25^{\circ}C$	C_{oes}	180		pF
反向传输电容 Reverse transfer capacitance			C_{res}	23		pF
门极电荷 Gate charge	$I_C=75A, V_{GE}=\pm 15V,$ $V_{CE}=600V$	$T_{vj}=25^{\circ}C$	Q_G	260		nC
集电极-发射极截止电流 Collector-emitter cut-off current	$V_{CE}=650V, V_{GE}=0V$	$T_{vj}=25^{\circ}C$	I_{CES}		1	mA
栅极-发射极漏电流 Gate-emitter leakage current	$V_{CE}=0V, V_{GE}=20V$	$T_{vj}=25^{\circ}C$	I_{GES}		200	nA
开通延迟时间 Turn-on delay time	$I_C=75A, V_{CE}=300V$ $V_{GE}=\pm 15V, R_G=8\Omega$ (电感负载) / (inductive load)	$T_{vj}=25^{\circ}C$ $T_{vj}=175^{\circ}C$	t_{don}	22 23		ns
上升时间 Rise time	$I_C=75A, V_{CE}=300V$ $V_{GE}=\pm 15V, R_G=8\Omega$ (电感负载) / (inductive load)	$T_{vj}=25^{\circ}C$ $T_{vj}=175^{\circ}C$	t_r	30 34		ns
关断延迟时间	$I_C=75A, V_{CE}=300V$	$T_{vj}=25^{\circ}C$	t_{doff}	108		ns

Typical Characteristics

Turn-off delay time	$V_{GE}=\pm 15\text{ V}$, $R_G=8\Omega$ (电感负载) / (inductive load)	$T_{vj}=175^\circ\text{C}$			132		
下降时间 Fall time	$I_C=75\text{ A}$, $V_{CE}=300\text{ V}$ $V_{GE}=\pm 15\text{ V}$, $R_G=8\Omega$ (电感负载) / (inductive load)	$T_{vj}=25^\circ\text{C}$ $T_{vj}=175^\circ\text{C}$	t_f		65 114		ns
开通损耗能量 (每脉冲) Turn-on energy loss per pulse	$I_C=75\text{ A}$, $V_{CE}=300\text{ V}$ $V_{GE}=\pm 15\text{ V}$, $R_G=8\Omega$ $di/dt=1800\text{ A}/\mu\text{s}$ ($T_{vj}=175^\circ\text{C}$) (电感负载) / (inductive load)	$T_{vj}=25^\circ\text{C}$ $T_{vj}=175^\circ\text{C}$	E_{on}		0.67 1.00		mJ
关断损耗能量 (每脉冲) Turn-off energy loss per pulse	$I_C=75\text{ A}$, $V_{CE}=300\text{ V}$ $V_{GE}=\pm 15\text{ V}$, $R_G=8\Omega$ $dv/dt=6700\text{ V}/\mu\text{s}$ ($T_{vj}=175^\circ\text{C}$) (电感负载) / (inductive load)	$T_{vj}=25^\circ\text{C}$ $T_{vj}=175^\circ\text{C}$	E_{off}		0.95 1.56		mJ

二极管/Diode

最大额定值 / Maximum Ratings

Parameter	Conditions	Symbol	Value	Unit
反向重复峰值电压 Repetitive peak reverse voltage	$T_{vj}=25^\circ\text{C}$	V_{RRM}	650	V
连续正向直流电流 Continuous DC forward current	$T_C=100^\circ\text{C}$, $T_{vj\text{ max}}=175^\circ\text{C}$	I_F	75	A
正向重复峰值电流 Repetitive peak forward current	$t_p=1\text{ ms}$	I_{FRM}	300	A

特征值 / Characteristic Values

Parameter	Conditions	Symbol	Value			Unit
			Min.	Typ.	Max.	
正向电压 Forward voltage	$I_F=75\text{ A}$, $V_{GE}=0\text{ V}$ $I_F=75\text{ A}$, $V_{GE}=0\text{ V}$ $I_F=75\text{ A}$, $V_{GE}=0\text{ V}$	$T_{vj}=25^\circ\text{C}$ $T_{vj}=150^\circ\text{C}$ $T_{vj}=175^\circ\text{C}$	V_F		1.55 1.70 1.68	2.0 V
反向恢复峰值电流 Peak reverse recovery current	$I_F=75\text{ A}$, $-di_F/dt=1800\text{ A}/\mu\text{s}$ ($T_{vj}=175^\circ\text{C}$) $V_R=300\text{ V}$, $V_{GE}=-15\text{ V}$	$T_{vj}=25^\circ\text{C}$ $T_{vj}=175^\circ\text{C}$	I_{RM}		37 51	A
反向恢复电荷 Reverse Recovered charge	$I_F=75\text{ A}$, $-di_F/dt=1800\text{ A}/\mu\text{s}$ ($T_{vj}=175^\circ\text{C}$) $V_R=300\text{ V}$, $V_{GE}=-15\text{ V}$	$T_{vj}=25^\circ\text{C}$ $T_{vj}=175^\circ\text{C}$	Q_{rr}		1.20 3.34	μC
反向恢复时间 Reverse Recovery Time	$I_F=75\text{ A}$, $-di_F/dt=1800\text{ A}/\mu\text{s}$ ($T_{vj}=175^\circ\text{C}$) $V_R=300\text{ V}$, $V_{GE}=-15\text{ V}$	$T_{vj}=25^\circ\text{C}$ $T_{vj}=175^\circ\text{C}$	t_{rr}		70 153	ns
反向恢复损耗 (每脉冲) Reverse recovered energy	$I_F=75\text{ A}$, $-di_F/dt=1800\text{ A}/\mu\text{s}$ ($T_{vj}=175^\circ\text{C}$) $V_R=300\text{ V}$, $V_{GE}=-15\text{ V}$	$T_{vj}=25^\circ\text{C}$ $T_{vj}=175^\circ\text{C}$	E_{rec}		0.23 0.74	mJ

Typical Characteristics



图 1. 典型输出特性 ($V_{GE}=15V$)

Figure 1. Typical output characteristics ($V_{GE}=15V$)

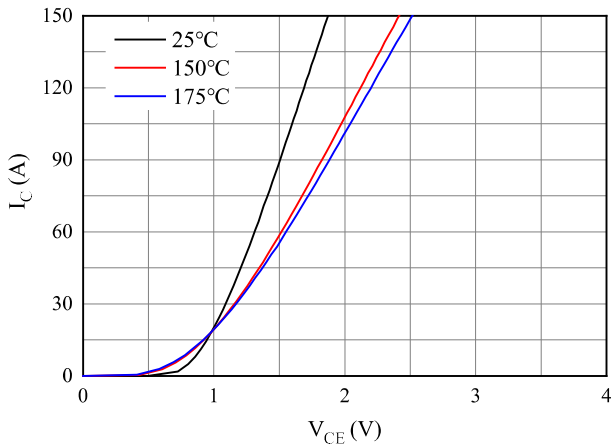

图 2. 典型输出特性 ($T_{vj}=150^\circ C$)

Figure 2. Typical output characteristics ($T_{vj}=150^\circ C$)

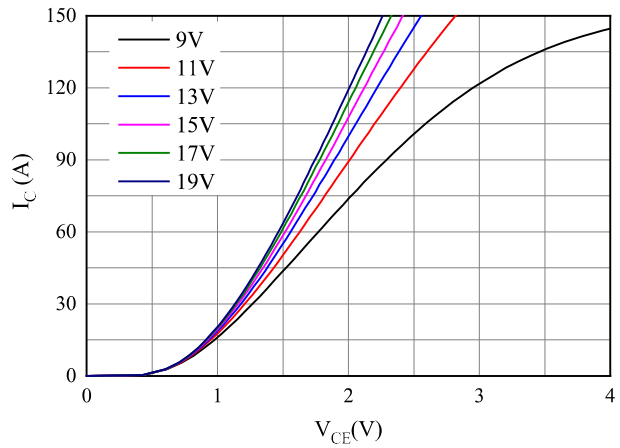

图 3. 典型传输特性 ($V_{CE}=20V$)

Figure 3. Typical transfer characteristic ($V_{CE}=20V$)

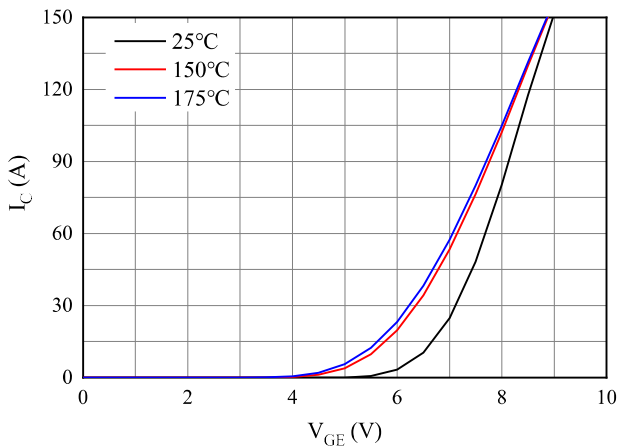

图 4. 正向偏压特性 二极管

Figure 4. Forward characteristic of Diode

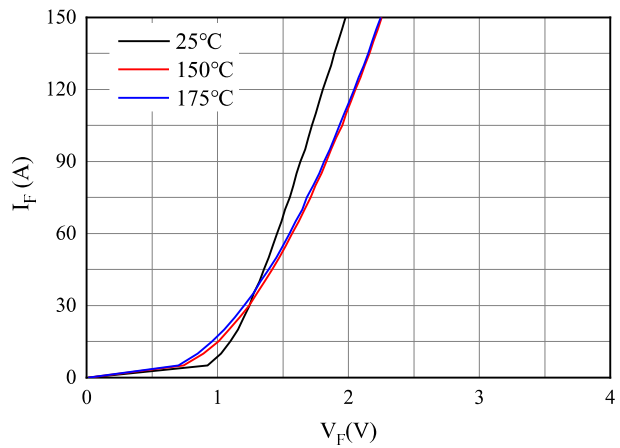

图 5. 瞬态热阻抗 IGBT

Figure 5. Transient thermal impedance IGBT,
 $Z_{thJC}=f(t)$

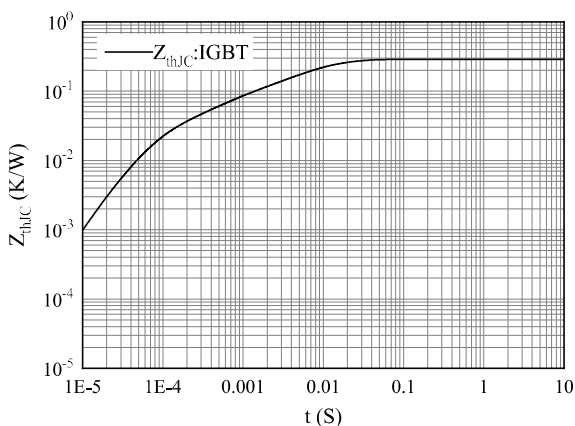

图 6. 瞬态热阻抗 FRD

Figure 6. Transient thermal impedance FRD,
 $Z_{thJC}=f(t)$

Typical Characteristics

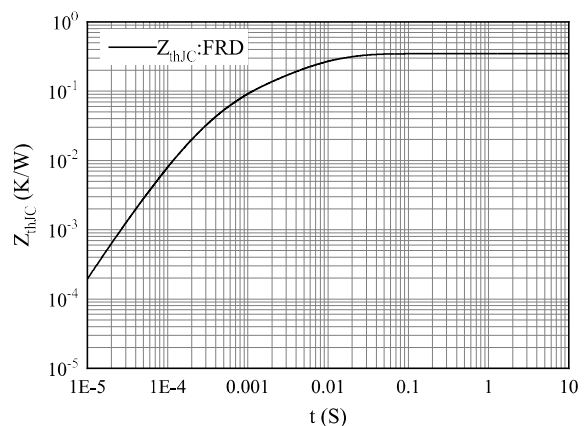

图 7. 开关损耗

Figure 7. Switching losses of IGBT
 $V_{GE} = \pm 15V$, $R_{gon} = 8\Omega$, $R_{goff} = 8\Omega$, $V_{CE} = 300V$

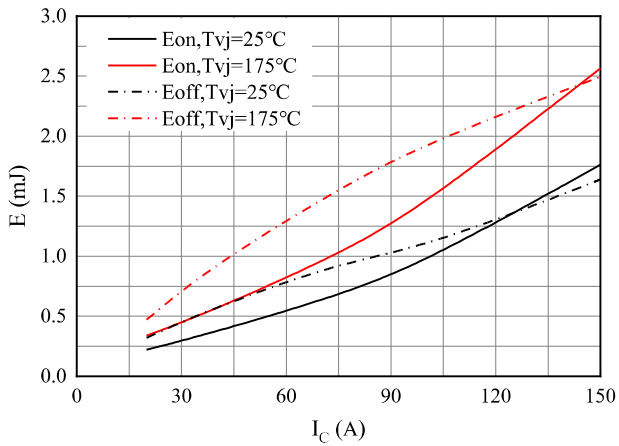

图 8. 开关损耗

Figure 8. Switching losses of IGBT
 $V_{GE} = \pm 15V$, $I_C = 75A$, $V_{CE} = 300V$

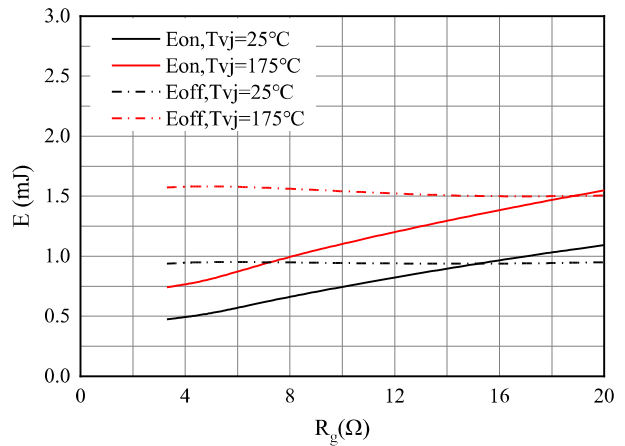

图 9. 开关损耗 二极管

Figure 9. Switching losses of Diode
 $R_{gon} = 8\Omega$, $V_{CE} = 300V$

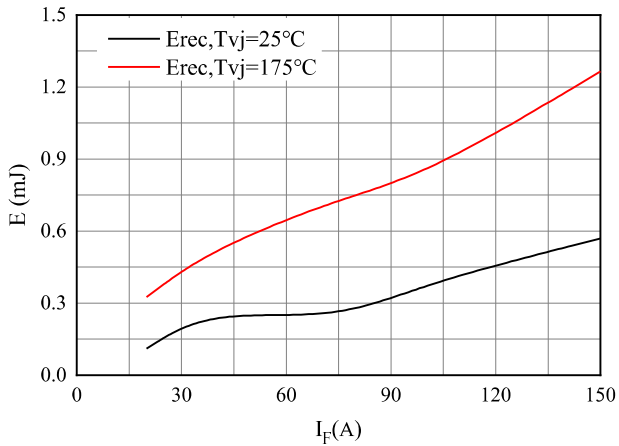

图 10. 开关损耗 二极管

Figure 10. Switching losses of Diode
 $I_F = 75A$, $V_{CE} = 300V$

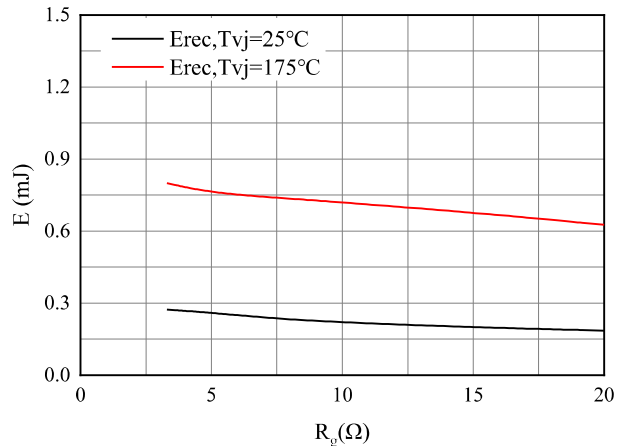

图 11. 电容特性

Figure 11. Capacitance characteristic

Package Outline Dimensions

接线图 / Circuit diagram

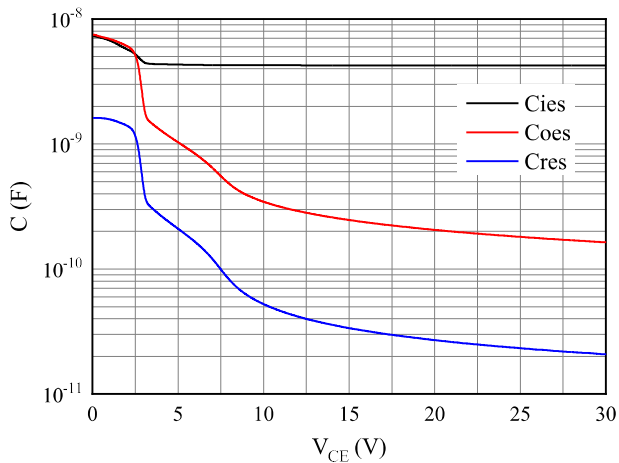
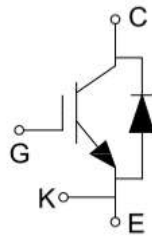

封装尺寸 / Package outlines

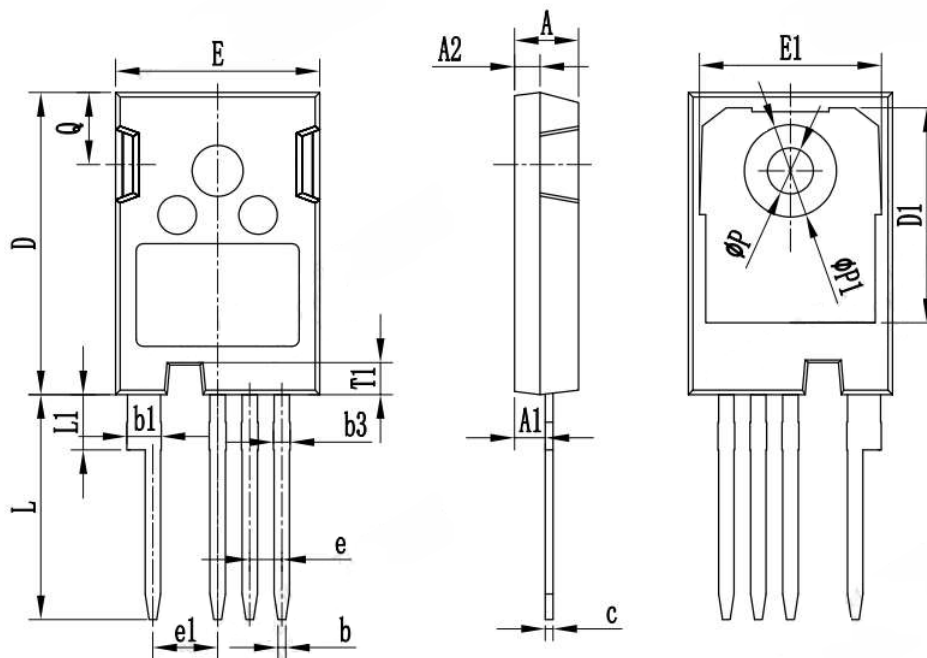

符号	单位:mm		
	MIN	NOM	MAX
A	4.80	5.00	5.20
A1	2.21	2.41	2.61
A2	1.8	2.00	2.20
b	1.06	1.21	1.36
b1	2.33	2.63	2.93
b3	1.07	1.30	1.60
c	0.51	0.61	0.75
D	23.30	23.45	23.60
D1	16.25	16.55	16.85
E	15.74	15.94	16.14
E1	13.72	14.02	14.32
T1	2.35	2.50	2.65
e	2.54 BSC		
e1	5.08 BSC		
Q	5.49	5.79	6.09
L	17.27	17.57	17.87
L1	3.99	4.19	4.39
phi p	3.40	3.60	3.80
phi p1	7.19 REF		